

NO. 00-00

WELCOME TO THE CBA 2024



# CALIFORNIA BLACKSMITH

CALIFORNIA BLACKSMITH ASSOCIATION

WELCOME  
TO THE CBA



# IN-PERSON EVENTS



*2 California Blacksmith*

*Welcome to the CBA*

# PRESIDENT'S MESSAGE

Welcome to the California Blacksmith Association (CBA). Currently, I am the president of the CBA board of directors, although I expect that will have changed by the time you read this message.

The CBA is a very active group, attracting diverse individuals from all over the state and beyond. We produce a newsletter similar to this one, multiple times a year, and we hold at least 4 in-person events annually – *see the opposite page*.

## What can you expect from us?

**Education:** The CBA has a very robust education system, with workshops and instructors up and down the state that teach classes on a regular basis, and at CBA events. Our website (*calsmith.org*), together with our YouTube® channel (*California Blacksmith Association*) hold a variety of educational resources for blacksmiths anywhere, and are available regardless of CBA membership.

**Zoom workshops and coaching:** This is something that we fell into during the COVID pandemic, and we found it so useful, that we're not even going to attempt to get it back into the bottle. The CBA has three blacksmith certification levels, if you're interested in that style of learning, and we have a group of excellent instructors that teach these skills in an online setting. Most classes usually involve related, small group, coaching sessions where you can check your progress and get useful tips on how to proceed.

**In-person events:** Our largest event is the Spring conference, and that moves around California from year to year. The conference attracts up to 450-500 members, and feature demonstrations, lectures and slideshows from both local and world renowned smiths, There are also hands-on educational opportunities, tailgate sales, raffles and auctions, together with food and a great social scene. Our other CBA events follow a very similar theme.

**Facebook:** We have a Facebook group page called *CBA-California Blacksmith Association*. It's a free service to smiths across the world, and it's a place where we post about upcoming events or news.

## What do we expect from you?

Firstly, we have harassment and safety policies that we expect you to adhere to. We promote a safe, friendly atmosphere, and we'd like it to stay that way.

**Join in:** Attend one of our in-person or online events. If you're an experienced smith please consider joining our team of instructors.

**Volunteer:** We need a host of volunteers to help out at our in-person events, or maintain our equipment. Our board of directors have various committees such as finance, publishing, social media, conference and others. If you bring those skills to the table, we'd like to talk to you. Volunteering is a great way to meet new friends and get involved with the group.

I look forward to seeing you at an event in the near future, and again, welcome!

Dennis Dusek



*Dennis Dusek  
CBA Board President*

# EDUCATION



*Victoria Ritter  
Education Committee Chair*

Welcome to the CBA.

As education chair, I try to have a CBA instructor/student 'cheat-sheet' in every issue of the *California Blacksmith*, our magazine.

To give you an example of what that looks like, here is a

recent article that appeared in the March/April issue of this year.

...last issue I looked at forging a hot-cut chisel, from the struck end down to the working end. Making a fuller in a similar manner just keeps the growth in width in check.

A chisel is a fuller, a very sharp fuller, but brings to the forefront the fact that fullers come in all shapes and sizes.

A matched hand-held fuller and 'Z-bar' (a bottom fuller) are a CBA level-1 curriculum project. The guide calls for a 3/8-inch in diameter for both tools.

The size doesn't really matter so long as both tools are matched in size. Try different sizes to see what works for you.

The purpose of the matching fullers is to allow you to divide and isolate material; think about how a tenon needs to be cleanly separated from the rest of the bar. Once the material is isolated, you can forge it into the shape needed.

The size of the fullers will dictate how that isolation occurs. The bigger the fuller, the more material that will be dragged down into the groove you are creating as you work.

That dragging of material will leave a rounded edge behind the groove, if you ultimately want a sharp edge (again, think of a tenon), you will need to outsmart the metal by adding or upsetting material into the parent bar before fullering.

The size of the upset will be dictated by the size of the fuller you plan to use.

A smaller fuller will leave material and minimize the drag, but now you need to make sure you don't impact the material on the other side of the groove when working.



*Matched top and bottom fullers from the CBA curriculum*

The groove will be so small, avoiding an errant hammer blow will be a good learning experience in hammer control.

What size works best will be up to you. I generally go for a 1/4-inch to make tenons but have 3/8-inch on hand as well.

All this talk about drag and getting it just right brings to mind another issue with using hand tools. It takes a third hand!

One to hold the hammer, one to hold the tool and another to hold the material. Typically, folks hold the material between their legs with or without tongs. Wearing a soft apron helps here.



*Using both tools on a clean bar requires a bit of a balancing act, and three hands... tool, bar & hammer*

# EDUCATION

On top of all that, the groove you make must be placed evenly and straight all the way around the bar while balancing it on the z-fuller and making sure the top fuller is placed directly over that. Whew. That is a lot all at once.

I would like to offer you another option. Use the z-fuller to set the groove in place. Hold the material, hot, on the z-fuller and hammer directly on the material creating a groove with the z-fuller.



*To start, create a shallow divot on one side of the bar*

Turn the piece 180 degrees, line up the initial groove with the z-fuller and create a second indent. With the two grooves in place, you can now perform the juggling previously described but with the added benefit of having the indent for both fullers in place.

Work methodically and evenly and you will be isolating material like a pro in no time.

Happy fullering and remember “Don’t just smith, smith better”, be a part of the CBA.

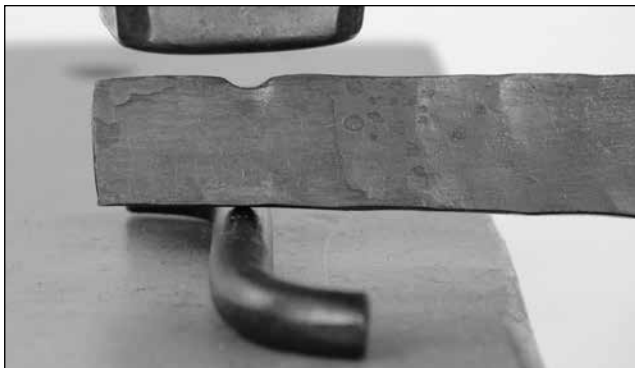

*Turn the bar over and repeat the process. Now you have landmarks for your matched top & bottom fullers*

Welcome to the CBA



*Having the divots in place really helps reduce the balancing act, and aids accuracy when combining the tools*



*Never fuller to the full depth that you require. Hammering will also add to the fullered depth*

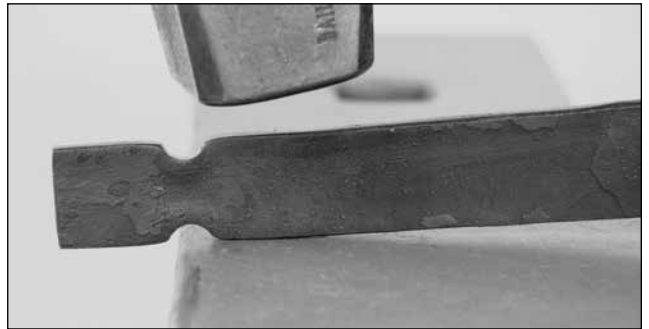

*The 3/8" fuller gives space for your hand hammer, the 1/4" fuller requires more accuracy*

## Cheat sheet

### Fuller

- Start: 7.5" in length
- End: 1/4" to 3/8" round end, finished total length ~ 8 inches; No sharp edges or corners.
- **Z-fuller**
- Start: 3/8" round 6" long
- End: ~1" from each end, bend 80-85° - twist to align both ends if necessary.

*Victoria is a nationally recognized blacksmithing instructor, and regularly teaches at both regional and national conferences, as well as craft schools.*

California Blacksmith 5

# SPRING CONFERENCE

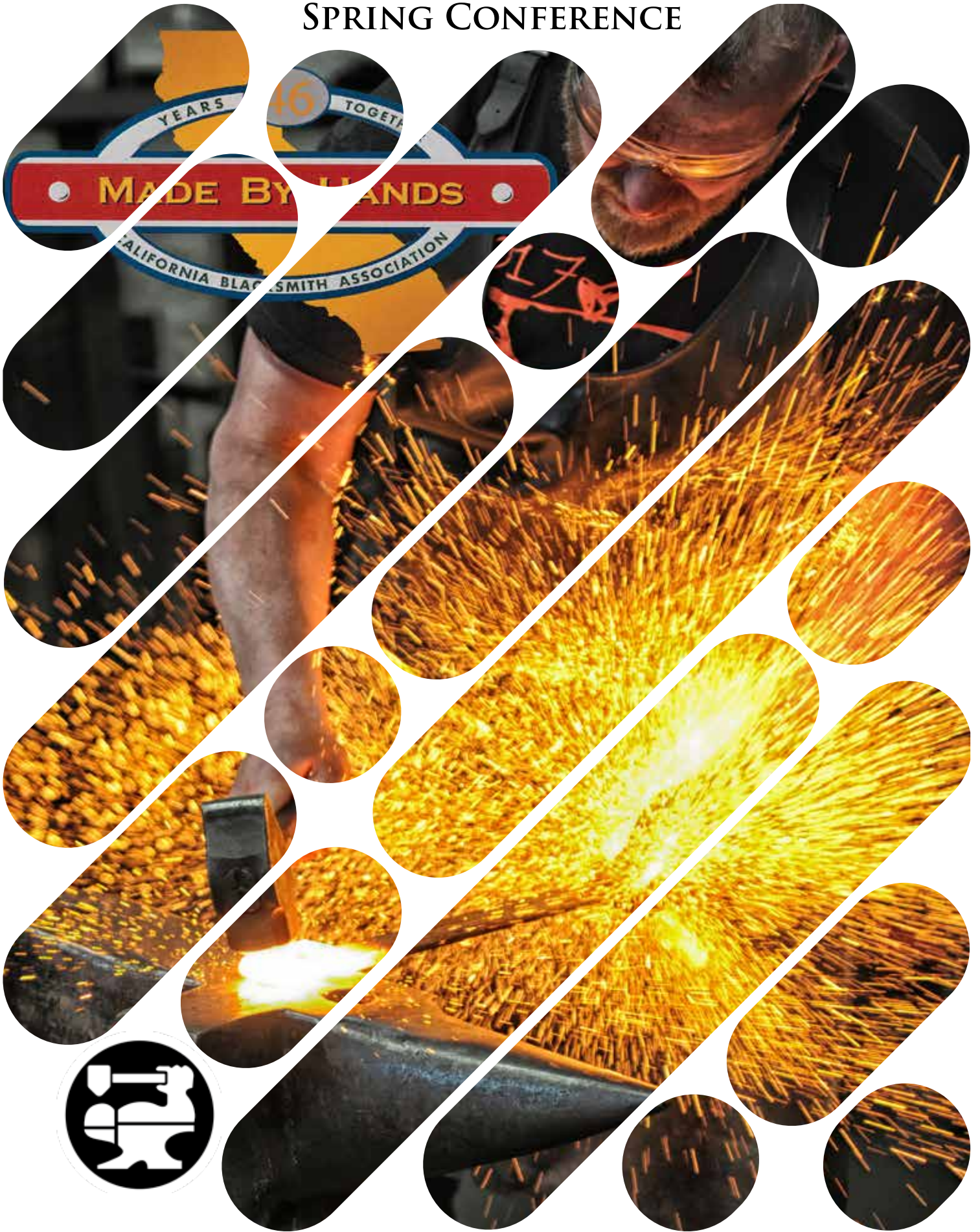

# ART & DESIGN

Ellen Durkan  
Artsy Stuff



One of the subjects that I find often lacking from the main subjects of blacksmith speak is that of design. Specifically, I find that there is very little dialogue of how a design was conceived of initially and what steps brought it to its final form; how did the design evolve to its final form?

For my CBA Spring Conference 2023 demo project, I wanted to integrate the passage of time with a humanoid. The COVID apocalypse and other closer to home life events had brought this idea home to me.

Time, for living things at least, is somewhat finite – no-one gets out of here alive. That concept brought me to the idea of a sand-filled hour-glass.

And while the hour-glass can be turned over and re-started each time the glass runs out, signifying renewal I suppose, I didn't feel that was what I wanted to say for this project. I wanted a definite end to the process, once the sand has gone, it's gone, and you "shuffle off this mortal coil".

Secondly, I wanted the object to be wearable, as that's my thing. The question was to either make the object a yoke – the pressure of time, or to make it light and ornate – enjoy the time that you have. I opted for the latter.

More than that, I wanted to show that we humanoids can wear the mantle of time regally, choosing how we spend our time, rather than have time be a crushing yoke.

I like neck pieces, but my initial thought was that this had to be bigger, more significant.

With those thoughts in place, I started to draw. I already have a style of neck-piece that I use, and from a practical point of view, I know how long it takes to make in a demo setting.

That was my starting point. I knew that I wanted more of a shoulder worn jewelry piece, so I drew the basics of my necklace, and worked my way out to the shoulders.

What I would like to show is my progression from that initial piece to the final design on the drawing board, and then, as we are blacksmiths after-all, I'd like to show how I made the piece....

I start with a basic form, in this case one with feminine attributes. Over the form I penciled in my neck piece but, as I wanted regal, I opted for a shoulder worn livery with the trappings of finery.

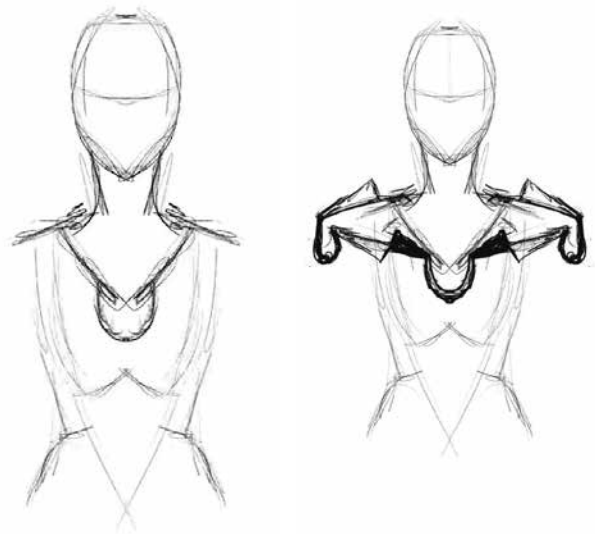

To capture the regal aspect of the design, I tried to stay away from sharp angles and pointy bits. Sharp pointy bits evoke a feeling of stress or anxiety, not really attributes that I associate with regal behavior.

I want to show that the wearer of the livery, while aware that time is passing, is calm and composed. As such, I made a conscious decision to round out corners, finials, and transitions where possible. I kept some corners to make the piece a little prickly, in an effort to make the wearer appear alone.

# ELLEN DURKAN

I didn't want to create the feeling of sleepy-time, so relaxed that the wearer doesn't care about time, I want to create a feeling of aware but composed. To that end, I have kept some sharp bits, but I have made sure that they are not overly sharp.

To further my efforts to show control, I have added a detail that centers the piece in the middle of the chest. I am trying to show balance. In an effort to frame the center piece, and to help define the wearers body I have placed two twirly bits.

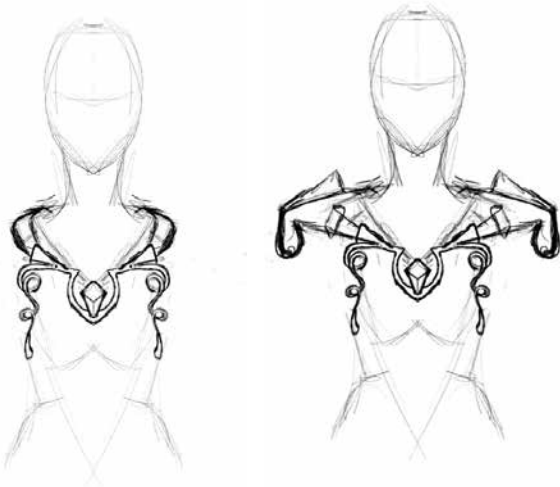

The twirly bits are important in that they help focus the viewer's attention to the central element at the chest.

Odd numbers such as three or five are easily divided sub-consciously, with the eye coming to rest in the middle – my 'In-Balance' piece. I kept the ends of twirly bits heavy, as they also help to frame the center element.

With the next two images, I added the time pieces, hollow stemmed flowers filled with sand. I cannot say that I was happy with the way that they looked, being either too clunky or too weak in my opinion.

Staying with odd numbers, I removed two of the flowers bringing my design into a five-piece format. I simplified the stems to straight drops with heavier ends. Note that the ends are angled, sloping towards the center piece at the chest.

8 California Blacksmith

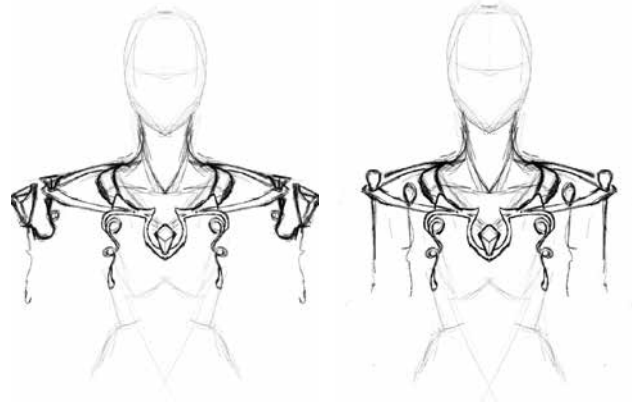

At this stage I started to add some details to the main frame of the livery. Again, note that any angles are bringing the viewer in towards the wearers head and neck, the centerline of the body.

I've drawn the hair to match these angles, again to center the body and the viewer's eye.

The bottom of the hair is drawn to match the slopes of collar bone frame embellishments.

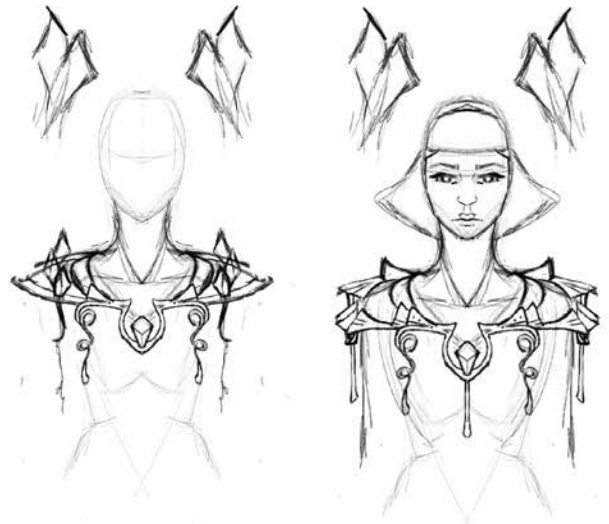

I want you to look at the frame that runs along the collar bone on the right-hand image above, note how two flared pieces are together and one flared piece is on its own.



Think of a set of balance scales, the two pieces together have a certain mass which can only be balanced by a single piece (think threes) some distance away.

Welcome to the CBA



# ART & DESIGN

If the single piece were close to the mass of the two pieces, it wouldn't balance on the scales.

I don't know if you can see from the pictures below (left), but there are three dots on the flared pieces at the front, and they follow the same format, two dots close together and one set apart – but all three are balanced.

I'm still not completely happy with the result. I've added some laminate pieces to the lone piece of the three flared pieces at the collar bone.

I've added them in such a way that they do not add visual weight, upending my scales, but I have a tight group of three pieces, which bring interest and help the eye stay engaged for a little longer in that area.

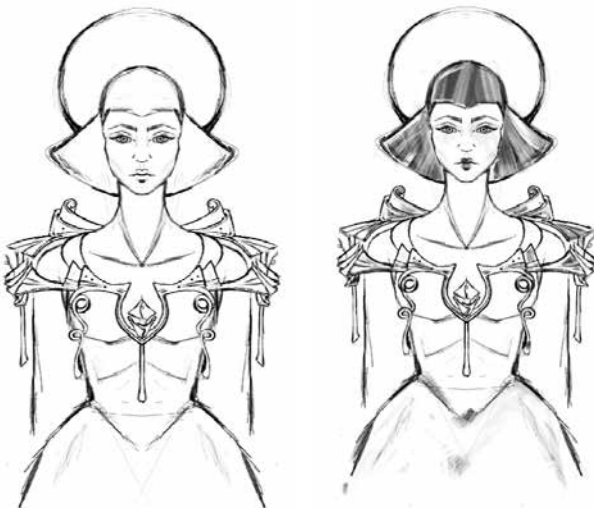

To offset there being more pointy things in the front, I have rounded the pointy bits at the back, at the sides of the neck.

The sphere at the head resembles the center piece at the chest.

...and this is where the rubber meets the road. After all the design thoughts, I still must make the piece within the given time frame of a conference demo slot.

What I need to do now is make some test pieces, adjusting as required... Have fun!

*Welcome to the CBA*

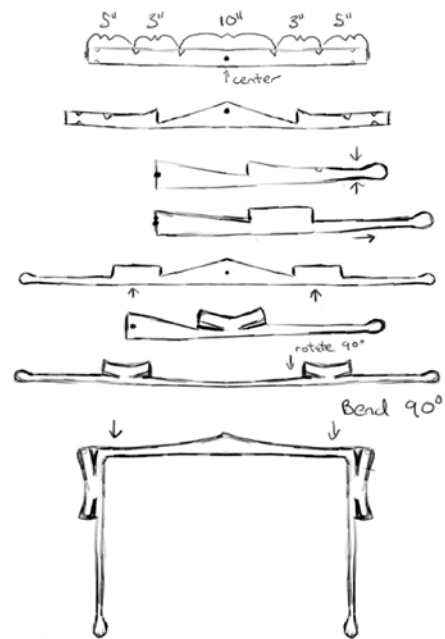

*California Blacksmith 9*

# KEYHOLE SPATULA

Becky Schimpff  
Forging a Traditional  
Keyhole Spatula



Thanks to the laws of physics, we know that metal moves in predictable ways. If we are not getting the desired

result, it is likely that we are asking the metal to defy physics and we need to modify our actions.

Forging a keyhole shape by spreading the material is an excellent exercise in the concept of working with the physics of metal.

This article will look at how to ensure a predictable outcome (setting yourself up for success) while also introducing solid blacksmithing techniques that will level-up your skill set beyond this project.

There are several ways to approach forging a keyhole shape. The issue we face is one of shape.

We can spread a flat bar and then trim to suit, but that's time consuming and wastes material.

Dressing the material from the side after spreading is also not available to us as the material will buckle and not upset cleanly.

We need to isolate and then manipulate the material to create a given outcome before we start to spread, creating a pre-shape to the bar prior to spreading. A shape that will yield a predictable outcome later in the forging process.

One option is to forge the keyhole by necking-in the width of the material at various points using one of many methods available to us:

- You can use the edge of your anvil and the peen of your hammer
- Matched top and bottom fullers,
- Fullering dies in a guillotine tool
- A spring swage.

All are valid approaches to forging shapes, however, necking-in the material in this situation

reduces the width and has the potential to create a problem, we can lose control of the material as we spread the bar, the bar will bend at the neck due to the forces of your hammer swing.



Thankfully for all of us, there's an alternative!

Instead of necking-in the stock as we go, we can forge strategically placed tapers, isolating specific material in advance so that our spatula naturally spreads out to our desired shape as we work. Now we have the set-up for a predictable outcome that will be less bothersome.

By putting the mass where we need it in advance, we can stay ahead of that 3:1 ratio of width to thickness ratio that causes the material to buckle rather than upset when struck on edge.

This concept is easily transferred to many blacksmithing projects. If you've made the Level-I slot punch, for example, you might remember that one step is to remove the excess mass at the working end for just this reason. You are setting yourself up for success.

Let's do some forging!

# BECKY SCHIMPF

We are going to forge our spatula from  $\frac{3}{4}$ -inch x  $\frac{1}{4}$ -inch flat bar. You can use other sizes of stock, just keep that 3:1 ratio in mind so that you are not fighting the metal as you forge the handle.

Our first step is to mark the bar where we want to create these strategic tapers. The bottom of the keyhole is essentially a trapezoid (a triangle with the top cut off) and the top of the keyhole is a large circle.

We can set-up the trapezoid with a reverse taper on the flat of the bar, leaving the bar thickest where we need the material to spread widely, and less thick where we don't need as much of spread.

Another taper will create the circle needed. This taper is much shorter and will run in the opposite direction to the first. The trick is to leave a pillow of material between the two tapers to form the circle.

Mark your bar with chalk or a silver pencil at 2" from the end of your bar and then again at  $\frac{1}{4}$ " from that first mark. You can play with these dimensions, just note that it is easier to get the hang of spreading material with shorter lengths.

With the bar marked, we can forge the two tapers required.

Using half-faced blows on a well-rounded near-side edge of your anvil, hold the bar at a slight angle and shoulder the bar at the 2" mark.

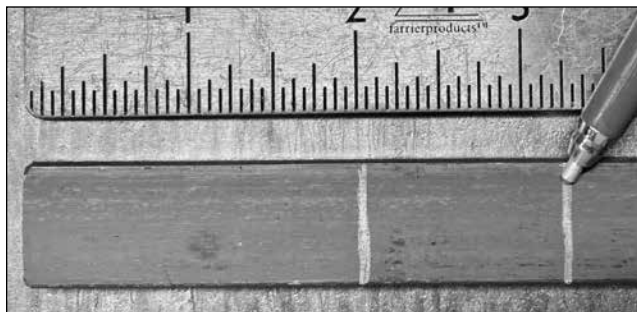

*I've marked the shoulders on the stock, but for the first shoulder at the 2" point, you might be better to put a chalk mark on the anvil, 2" from the near-side edge*

Create a shoulder that is about  $\frac{1}{2}$  the thickness of the bar. Note that this thickness will determine the width of the narrowest part of the keyhole (we'll cover how to calculate expected spread later in this article) and you can adjust the thickness as desired to change this narrowest dimension.

Maintain your angle and forge a reverse taper from the shoulder to *not quite* the end of the bar.

Take care not to thin the very end of the bar as this will become the widest part of your trapezoid; we definitely want to maintain the full thickness of the material at the end.

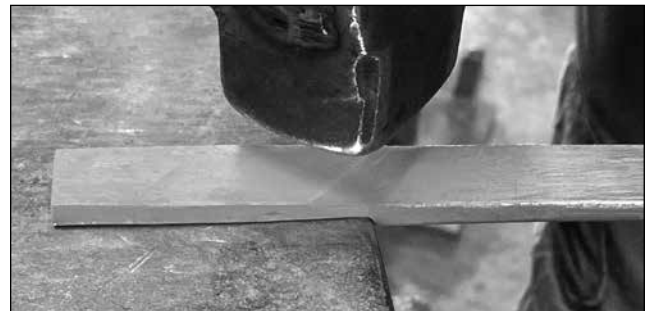

*Hold the bar at a slight angle from horizontal as you forge in the first shoulder*

Now we'll set-up for the circle. Move to a rounded edge of the off-side of your anvil and using a slightly steeper angle, repeat the indentation process at the second mark.

This time taper the bar in the other direction, towards you. The space that you've isolated between the two tapers will become the top of the keyhole, the circle.

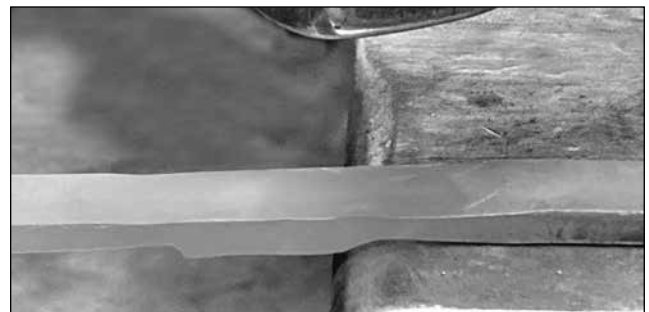

*Lay-off  $\frac{1}{4}$ " from the offside edge and set down another shoulder. Working over a soft edge will prevent cold shuts from forming during spreading*

# KEYHOLE SPATULA



*Here is the result of forging both shoulders of the “set-up”, something that will yield a predicable outcome later in the forging process*

Now we have mass where we need it. The beauty of setting it up this way is that when we go to spread the material it will naturally form a keyhole shape!

To spread the material, we are going to use the peen of our hammer. For this exercise you will need to have a well-dressed peen (rounded edges) that is wide enough to move material.

The ideal width for your peen is in the  $\frac{3}{8}$ " range, and it should be somewhat flat at the end not half round. A half round peen has a very defined pinch-point, something that we want to avoid. Be aware that if your peen is sharp or not well dressed, it will leave marks.

Our goal is to spread our stock until we get it to a thickness of  $\frac{1}{16}$ -inch and a width of  $2\frac{1}{4}$ -inch at the end of the spatula.

But wait a minute - if you are a math person following along here and calculating as we go, you might notice that things don't quite add up!

If you took  $\frac{3}{4}$ -inch x  $\frac{1}{4}$ -inch stock and cut it into four pieces  $\frac{1}{16}$ -inch thick you should get a 3-inch-wide bar that is  $\frac{1}{16}$ -inch in thickness. But that's not what happens when we spread the stock. So what's going on?

This goes back to the physics of the metal: when we spread material we don't get as much spread as would theoretically make sense.

Think of a rolling pin in pastry dough, most of the dough is bring rolled out in front and behind the rolling pin; most, but not all. Some dough is being moved to the sides of the rolling pin.

This is true of metal being spread under the peen of your hammer, most is travelling perpendicular to the peen, but a percentage is lost to an elongation of the material.

There's a rule of thumb to help remember this: you will get approximately 75% of the spread that you think you are going to get based on math (this varies somewhat by smith, peen, and heat source). So, for our  $\frac{3}{4}$ -inch x  $\frac{1}{4}$ -inch stock, if we flatten the stock to  $\frac{1}{16}$ -inch we can expect to get approximately a  $2\frac{1}{4}$ -inch spread, about 75%.

Now that we understand the math, and have set ourselves up for a predictable outcome with the strategic tapers, let's start spreading!

Start by dividing the material in to two halves by creating a trough or valley right down the center of the bar with your peen, starting at the end and working your way down the spatula.

Keep your hammer absolutely parallel to the stock as you work. Keep in mind you pre-solved the problem of the final shape in the last couple of heats. You only need to make even, parallel blows to get the spread right, to yield your predicable outcome from the initial set-up.



*Start in the center of the bar and create a trough*

# BECKY SCHIMPF



*Here is a view of the trough*

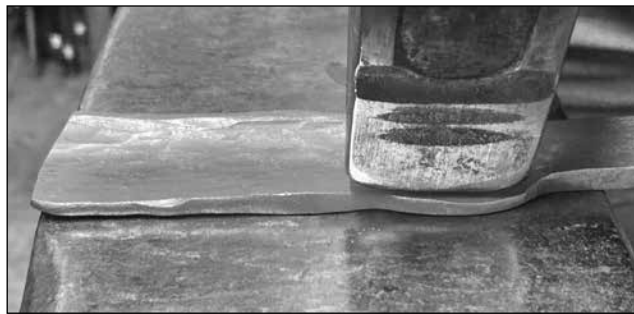

*Work the circle after the keyhole. Do a little and then catch up with your strong side*

Get the trough as close to the desired  $\frac{1}{16}$ -inch thickness as possible. You will notice a difference in the feel and sound of your hammer blow at the  $\frac{1}{16}$ -inch goal.

The purpose of this step is to push the mass out of the middle of the bar to the sides. It's difficult to get the mass out of the middle if you skip or underperform this step.

Once you've created the trough, spread the material to your weaker side, again using your peen. What do I mean by your weaker side? Peening away from your body is more difficult than peening towards your body due to the arc of the hammer as you work.

You'll be more likely to match your initial spread if you work your weaker side first and then come back and work your stronger side.

Please note that I'm not using the terms push or pull the material. You are using your peen as a fuller, dividing the material as you work. We do not push or pull top or bottom fullers.

First spread the trapezoid, working level to the bottom of the shoulder, and then spread the circle.

Note how easily the soft shoulders forge in without creating cold shuts.



*Work the keyhole first*



*Work to your weak side, away from your body*



*Now work the circle. Keep your hammer parallel to the centerline throughout the spreading sequence unless things go wrong*

# KEYHOLE SPATULA

Work the two sides until you get to your desired width and shape. This is a matter of working a little bit on each side, do a little and then catch up, do a little more...

You should see your keyhole start to take shape. You are aiming for  $\frac{1}{16}$ -inch thickness, with the widest part at the end of the trapezoid at approximately  $2\frac{1}{4}$ -inches in width, our 75%.

Keep the edges thick until you are close to finishing, so that they don't burn in the forge.

Examine your hammer blows on the spatula as you work. What you should see are clear peen marks equal to the length of your peen, and that the marks are parallel to the stock.

Here's a fun fact: *Spreading material gives up your secrets. Specifically, it will show if you tend to tilt your hammer to the front, the back or either side. For this reason, it is one of my favorite ways to pinpoint where correction may be needed, and has the potential to greatly improve your hammer blows.*

If you notice a problem with your spatula tilting to one side, you are likely not holding your hammer parallel to the bar. The material will spread perpendicular to your peen, just like the dough and the rolling pin.

If your problem is you are not getting the expected width, the mass is still in the middle. Be sure to get the middle to your desired thickness before you peen out the sides.

How can you tell? Because you will start to feel and hear the anvil as you approach the  $\frac{1}{16}$ -inch thickness, just as you do when punching a bar.

If you are still not getting the expected  $2\frac{1}{4}$ " width, or you are noticing that your spatula is lengthening more than expected, there are a couple or three things to consider.

The first two are easy: heat and strength of your hammer blow. If you are working at a low temperature or have a light hammer blow, you will not be forging efficiently, taking more trips to the anvil to complete your work.

The other reason is that you might be tilting your hammer to one side or the other, hitting with the corner of your peen.

Hitting with the corner will cause the spatula to lengthen at the cost of width. Look at your peen marks on your spatula and make corrections.



The height of your anvil can also influence your efficiency while forging. Having an anvil either too high or too low will affect your hammer swing.

If you still can't figure out the source, take a video of yourself. This is a great way to see things that you normally don't get to see.

You might not be surprised if I tell you, it is easier to fix what you are doing wrong than it is to fix the spatula once it has gone awry.

That said, if you have some slight variations in spread, you can correct by positioning your hammer perpendicular to where you want the material to go and carefully forging material to where it is needed.

One neat trick to determine if your two sides are even is to trace around your spatula with chalk and then flip it. You'll be able to see where the sides are different.

At this point, you should have a well-shaped keyhole. Our last step is to use the flat of your hammer to take out the peen marks. Do this final step at a dull red to black heat to planish the surface and knock off the scale.

# BECKY SCHIMPF

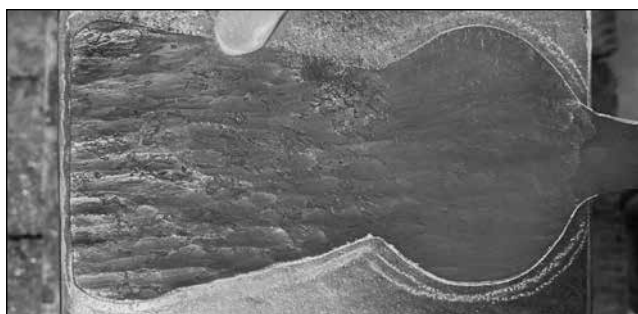

*Chalk around the perimeter of your spatula and then turn the blade over to check for symmetry*

You are now ready to clean up the edges and to refine the shape of your keyhole with a file. Do this at the vise with a hand file.

The keyhole spatula is a traditional shape that was used historically for fireplace cooking, with at least one spatula in every kitchen. There are many examples of some beautiful approaches to creating decorative handles.



*File the edges to suit at the vise with a hand file. Remember to keep the filing surface close to the jaws of the vise to avoid the squeal*

Spatulas were designed with a rat-tail, punched hole or other method to hang the utensil on a hook near the fireplace. They were often white-smithed (filed to finish) and elaborately decorated either with punch and chisel marks or with files.

Once you are happy with the shape of the whole utensil, you are ready to bend the blade of the spatula itself.



*Some examples of keyhole or thistle spatulas with decorative handles*

Imagine yourself flipping pancakes to get the feel for what angle works for you. You can bend in the vise or over the edge of the anvil, ideally use a hide or wooden mallet to avoid leaving marks.

Finish with a food safe finish such as beeswax or cooking oil.

*Becky is a National Curriculum Instructor, and is currently the chair of the ABANA Education Committee.*

*Becky regularly teaches at both CBA events and national events, as well as craft schools such as Adam's Forge in LA.*



*Bend over the offside edge with a rawhide mallet*

# JAKE TROGDON



## The Adjustable Anvil Stand Jake Trogdon - CBA

When blacksmithing there are many things that we need to pay attention to, from getting the correct heat, effective hammer blows, placement of the stock on the anvil, body position, keeping a good mental picture of what we are intending to make, etc. it can be overwhelming.

We generally want to set ourselves up so that we can focus on what we are forging and enjoy the process thoroughly.

One area that we have control over is the tooling that we are using at the time we're working, striving to have equipment that fits us and our work as best as it can.

Teaching and traveling have shown me that one of the most overlooked pieces of equipment is the anvil stand.

There is nothing more iconic than an anvil on a stump. While it does suit the need, the stump leaves something to be desired when it comes to functionality, such as the height, stability, sound, shape, and overall weight.

**Height:** The truth of the matter is that there is no ideal anvil height. The ideal height of the anvil is for the hammer swing to not be cut short by being overly tall or to be overextend with an anvil being too low.

For that to be determined we have to accept that it will change with the height of the smith, the height of the stock, and the nature of the tooling being used.

**Stability of the anvil:** We want the anvil to be secured as rigidly as possible so the force of our blows is transferred to the work.

If the anvil is unstable the energy of the blow is used up in the movement of the anvil. Imagine drawing over the horn and every blow is raising the heel of the anvil instead of moving the stock.

The more energy efficient we are, the longer we can learn and be engaged.

**Sound:** The ringing of the anvil not only causes damage to our hearing, but is also mentally taxing during a day's work.

A good stand can dampen that sound considerably. While there are many ways of dampening sound, the most effective is to bind the anvil as tightly as possible to the stand with a thin layer of material between, such as leather skirting, wood, etc. to absorb any anomalies at the anvil base.

**Shape:** The trusty stump does allow for a solid base but it is hard to make the bottom dead flat, as well as find a dead flat surface for the anvil.

One solution is utilizing a tripod design so that it will self-level. This also has the additional benefit of giving us some place for our feet to go as on the occasions when we get closer to the anvil.

**Weight:** While having a stand that has as much mass as possible is desirable in a shop setting, when traveling to a conference for example, it can be detrimental.

After taking as many of the above parameters into consideration, I tried to build an anvil stand.

Within this CBA article you will find a detailed drawing for an adjustable tripod stand with a chain binding system to secure the anvil.

The chains will accommodate a wide variety of anvil sizes and shapes and a good job of both securing and deadening the anvil.



# ADJUSTABLE ANVIL STAND

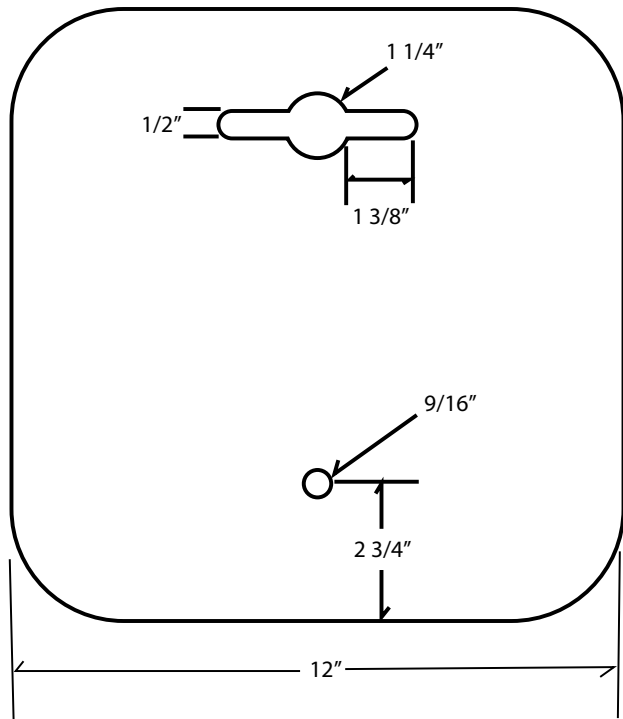
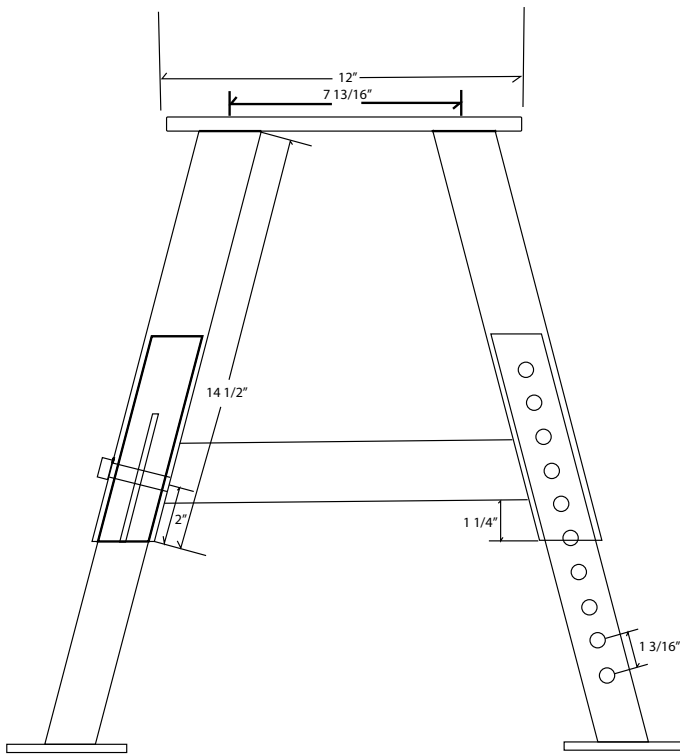

This stand is my primary stand, used with a 134 lb anvil, and I have been quite pleased with the performance and the ability to travel with it.

## Materials:

- Base Plate 1 @ 12" x 12" x 3/8" thick plate- utilize as heavy a plate as you are willing to move. 3/8" is adequate, thinner will work, thicker will be more solid.
- Outer legs - 3 @ 2" x 2" x 3/16" wall tubing - 14 1/2" long mitered 15° on both ends
- Inner legs - 3 @ 1 1/2" x 1 1/2" x 1/4" wall tubing - 14 1/2" long mitered 15° on both ends
- Bracing - 3 @ 1" x 1/4" flat bar - 14" long approx. You will cut to length later
- Feet - 3 @ 1/4" plate - 4" diameter circle
- Bolts & Nuts - 3 @ 1/2" x 3" flange bolt and nut - The flange is not required however it does give you more to weld to without fear of disturbing threads
- Chain - 3/8" chain - 3 ft.
- Eye bolt - 1/2" by 4" threads with washer and nut

I'll walk you through the construction of this stand as if you are working from a home shop with limited tools.

Let's start with getting the base sorted first. The 12" x 12" shape is most easily obtained from 12" x 3/8" bar stock, but you may be limited to plate steel.

It is efficient to lay out all of the centers and center punch them now, for reference later.

After cutting, radius the corners and edges for safety. I like to knock any cutting slag off with a chisel before using a grinding or sanding wheel. This makes the edges look crisp, and saves tremendously on consumables.

# JAKE TROGDON



*I chisel away most of the slag at the cut*

Slag is much harder than the parent material. I was told early on in my welding career that any part we make should be able to be tossed to someone without the risk of them being cut and I've taken that wisdom to heart.

I would rather a safe edge than a crisp line for any of my tools. Take the time after cutting to safe the edges up as you work through this project.



*Dress the edges of the cut. Make the edge safe for you or your co-worker*

Next all the legs need to be cut to a 15° mitre. This angle suites me well, and strikes a good balance between rigidity and making a large enough footprint for stability.

When cutting the outer leg ensure that the seam side is up in the saw. This will be to your advantage later when you are cutting the slots for the adjustable legs.



*Cut the end of all the legs to 15°. The cuts are parallel not opposite. Weld seam up or down*



*Here are my cut parts ready to be drilled and then assembled*

After cutting the legs out you need to drill  $\frac{9}{16}$ -inch holes to accommodate the bolts.

Start with the inner legs, on a face that has the perpendicular cut end, not an angled cut end.

Mark centerline all the way down one side, and make your first mark at 2  $\frac{1}{4}$ -inch. This has now become the bottom of the leg. Now mark out our adjustment holes at  $1\frac{3}{16}$ -inch on-center for the remainder of the length.



# ADJUSTABLE ANVIL STAND



*Drill all the holes and remove any swarf*



*Use a square or dividers to mark a central line along both sides of the outside legs*

I like to use a set of dividers again for this process. The number of adjustment holes may seem like an excessive amount of adjustability, but it allows for multiple sized anvils and tooling combinations such as heading blocks to be used.

On the outer leg you will only need to mark one hole at the 2-inch mark on the outside surface of the leg. Drill through both sides. This is now the bottom of the leg.

De-burr all drilled holes.



*The retaining bolt is 2" up from the bottom of the outside leg on the straight cut side*



*Use a "Zip" disc or other suitable media to cut the slots into the side of the outer legs*

After marking the centerline, make a mark at 4 1/2". You can drill this if you like with a 3/16" drill bit, but it is not necessary.

Next grind the slot with an appropriate flat hard disc. Notice that I do not have the portion that we are splitting held in the vice, preventing the disc from catching or burning up your grinder.

Take a file and clean up any sharp edges you have made with the cut.

Next you will make a slot in the outer leg to allow it to firmly grip the inner leg. Start by marking a centerline down the lower portion of the sides of the outer leg.

One of these sides should contain the seam, eliminating the need to file it out to make the lower legs fit within the upper, and removing any potential side to side movement during use.

The next step is welding the nut to the outer leg. I like to dip a bolt in MIG nozzle dip and thread through the leg and into the nut. This secures the nut in place and prevents any berries from sticking to the nut threads.

You may have to wait just a minute for the nut to cool to be able to remove the bolt.

# JAKE TROGDON



*Dip the threads of the bolt in anti-spatter dip before assembling the bolt through the leg and positioning the nut*



*Fully weld the nut in place. It may take a minute before you can un-thread the bolt*



*Here is a view both legs fitted together showing how the adjustment works*

Next you will lay out the placement of the legs on the plate. I prefer a single leg under the horn to allow for space to work and two legs under the heel for stability.

Using a combination square or speed square find center of the plate and mark out  $45^\circ$  to each rear corner, and straight to the center of the opposite edge. You are going to weld all the way around these legs so mark approx.  $1/2$ " back from the edge to give yourself space to place the welds.

*20 California Blacksmith*

And finally, mark off half the thickness of the legs to find the outer edge of one side. These marks do not require precision, but they help in placing the leg on the plate when welding later.

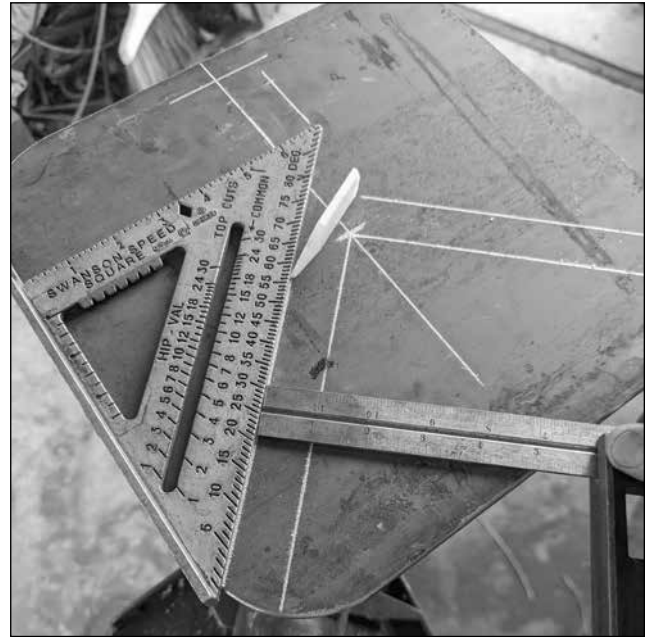

*Find center of the plate and come out  $45^\circ$  to 2 corners and perpendicular to the edge for the 3<sup>rd</sup> leg*

Whenever possible, when building something, I fully weld after everything has been tacked together, as this does several things:

- It helps control warping,
- Keeps the berries from interfering with the fit-up of later pieces
- Saves time by consolidating like actions together.

Trying to fit for a compound angle is difficult, and requires that you work one plane at a time.

Place the leg within our marks and lift it to give yourself about a  $1/8$ -inch gap at one corner; tack that corner in place.

Bring the leg over to make it square to the baseplate and tack the other corner. Don't worry about the  $15^\circ$  angle just yet, focus on getting the leg square to the plate.

*Welcome to the CBA*

# ADJUSTABLE ANVIL STAND



*In this case I've tacked the right rear corner of the leg and I'm now lifting the leg to square with the plate before tacking the left rear corner*

Lastly, lift the leg to the required 15° and tack the remaining corners.

Working in this order allows for good alignment of the leg and then welding when all legs are tacked allows the base to stay flat while laying out the legs.



*Now lift the leg into the correct angle and tack the two remaining corners*

When fabricating, and you do not have a beveled square, or want to protect your tool from sparks, etc., you can use two hacksaw blades (or similar) with a nut and bolt through one end to copy the angle from piece to piece.

*Welcome to the CBA*



*Tack all three legs into position before tacking the bracing bars onto the legs*

Next you will need to cut the leg bracing to fit at the bottom of the outer legs.

I went 1¼-inches from the bottom of the leg and made a mark on all three inside edges of the legs. This will be the bottom, or long, measurement for the braces. A piece of paper or cardboard can be cut to make a template and then transfer it to your bar stock.

Cut your braces and tack them in on the marks that we made on the legs. Another liberal application of nozzle dip on the nut and bolt won't hurt anything either!



*Make a template from card-stock to determine the size and shape of your bracing bars*

Next install your inner legs snugly and turn the stand over on a flat surface.

I drill a ½-inch hole into each of the feet plates to allow for the stand to be staked out or bolted to a floor if required at any future time.

*California Blacksmith 21*

The feet are round, as I've kicked too many stands with my shins to find square foot plates enjoyable anymore.

Place each of the feet under the legs and tack them to ensure that they are all on the same plane.



*Round, pre-drilled plate make the feet for the stand*

Once you have everything tacked in place, you can fully weld all of the joints you have tacked.

Try to distribute the welding as much as possible. When molten metal cools it shrinks and that shrinkage is what puts stress on the welds. Welding in different places makes sure we don't over stress a construction in any one place or direction.



*Once everything has been tacked in place, fully weld all seams. Distribute the heat as much as possible*

Now you are left with the attachments for the anvil tie downs. I like the chain method described here, as it has served me very well.

Mark out and center punch for two holes on what will be the nearside and offside edges.

The layout may depend on what anvil type you have, as some have upsetting blocks cast into the anvil, or may feature an oversized base.

One hole will be drilled at  $\frac{9}{16}$ -inch to allow the eye bolt to pass through. The other hole drill to  $\frac{1}{4}$ -inches.

I used an Oxy/acetylene torch to cut the large hole, but I have had good luck with carbide tipped hole-saw bits.

After you get the larger hole cut, measure off  $1\frac{1}{8}$ -inch in either direction and drill a  $\frac{1}{2}$ -inch hole. Join the  $\frac{1}{2}$ -inch hole to the larger hole using two  $\frac{1}{2}$ -inch wide slots.

I like to make two divots to receive the chain links on the bottom. This makes sure they cannot slip once tightened down.



*The bottom of the plate showing a method of retaining the ends of the chain. Chain fitted shown below*



The last step is to open the eye of the eye bolt and after finding the middle of the chain, slip the middle link into the eyebolt and weld the eye shut.

I do recommend a piece of leather or wood between the anvil and the stand as I find that it helps to reduce the ringing during use.  $\diamond$

# HA'PENNY SCROLLS



Mark Aspery  
The Ha'penny Scroll

The snub-ended scroll family consists of the Solid Snub end scroll and the Ha'penny (Half-Penny) snub end scroll. Both are somewhat similar in their method of construction.

Looking at the ha'penny scroll, *made from flat bar*, the ha'penny finial must be twisted through 90° from the parent bar, and then forged from a rough square shape to a final round shape.

All these moves require that you make the initial shoulder over a soft offside edge of the anvil to resist cracking during the twisting and shaping.

But, that extra material at the neck of the finial will present a problem later in the forging unless you take care of it.

Ultimately, we want a sharp transition from the scroll finial to the flat bar. We do not want the finial offset from the flat bar, and unless you take care of the stored material, that's what you will get, an offset scroll finial.

Think of a wheel rolling down a track - the point just in front of the contact patch between the wheel and the ground makes a sharp angle - our desired finial to flat bar outcome.

Now imagine a clump of hard dirt in front of the wheel. The wheel hits the dirt and crushes the clump - but the dirt does not go away, it might get crushed, but it does not go away.

The wheel rides up on the dirt and is now offset from the ground - our not-desirable finial to flat bar outcome.

Go too far over the dirt, and the bottom of your tire doesn't contact anything - in blacksmithing terms, that's a cold-shut or crack.

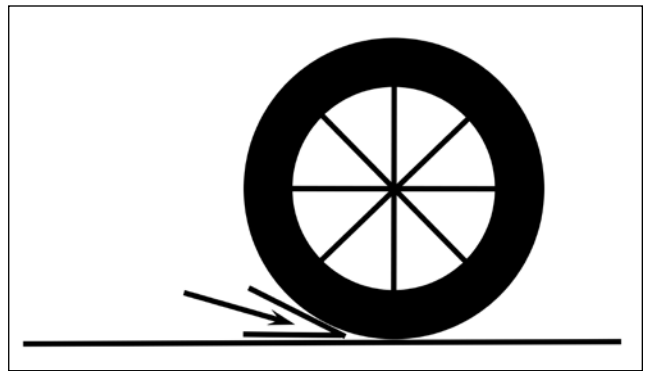

*The tire makes a sharp transition to the ground as the Ha'penny scroll should make to the parent bar*

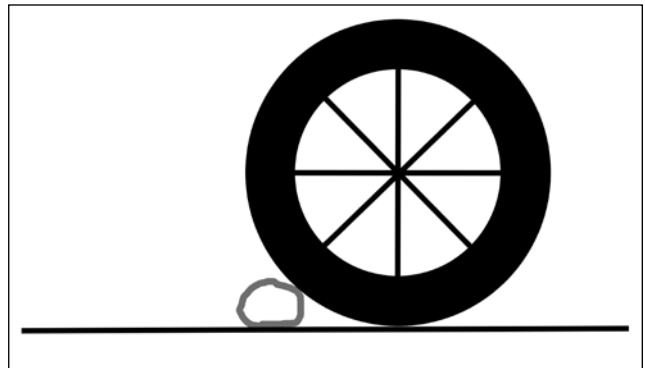

*A lump of hard dirt in front of the tire*

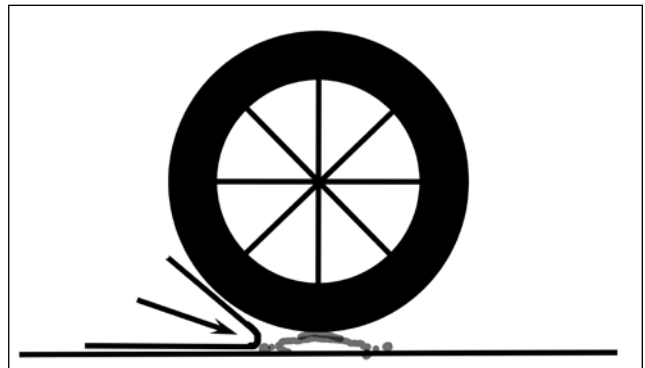

*The dirt is crushed, but it doesn't go away. The tire rides over the dirt and is raised above the ground*

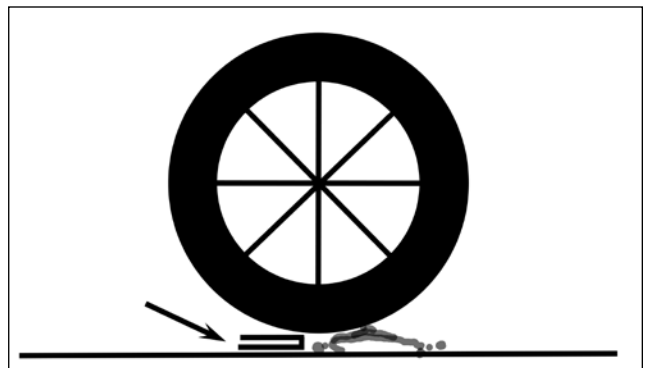

*At some point the bottom of the tire no longer connects to the ground - that would be a crack or cold shut*

# MARK ASPERY

Unless you take steps to remove the soft shoulder from in front of the ha'penny finial, your finial will look like the wheel on the pile of dirt.

Now that we have some of the preliminaries out of the way, let's make a ha'penny scroll.

I find that working with a farrier's rounding hammer yields great results when putting on the final shape of the ha'penny.

A half-penny in "old" British money measures 1-inch in diameter, and you can duplicate that size by working with a  $\frac{3}{4}$ -inch by  $\frac{1}{4}$ -inch flat bar.

Over a soft offside edge, lay off as much as the bar is wide over the edge - in this case  $\frac{3}{4}$ -inch.

Hold the bar at a slight angle and create a soft shoulder. Do not dress the growth in width at this stage. Take the shoulder down until the neck cross-section is  $\frac{3}{8}$ -inch square. Extend the taper for approximately 3-inches in length and keep it centered on the parent bar.

The taper to the parent bar will flow through the scroll finial eventually. More later.

To avoid damaging the "flag" of isolated material, work only from the back side as you take the square neck to a round(ish) cross section, with few corners or lines showing.

You need to make about  $\frac{3}{4}$ -inch or so round or close enough to round, as that's where the twist in the bar will be placed.



*Turn the bar 45°, and work from the top and sides only so as not to damage the 'flag' of material*

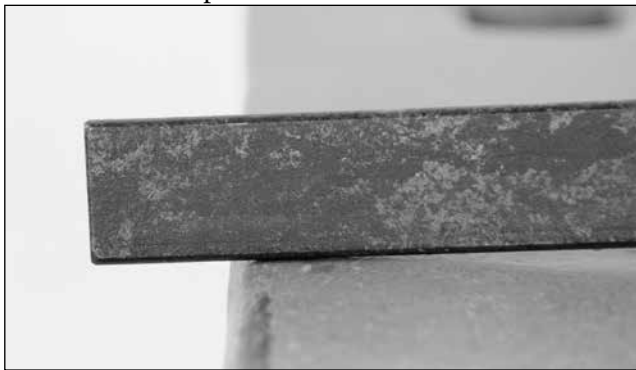

*Lay off from the offside edge as much as the bar is wide, in this case  $\frac{3}{4}$ ". Hold the bar at a slight angle*

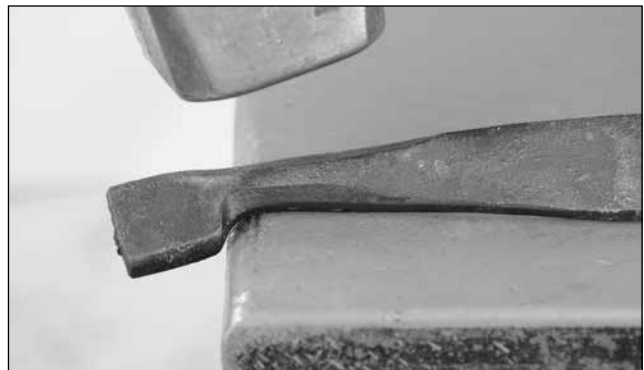

*Take about 1" of the neck to a true octagon shape*

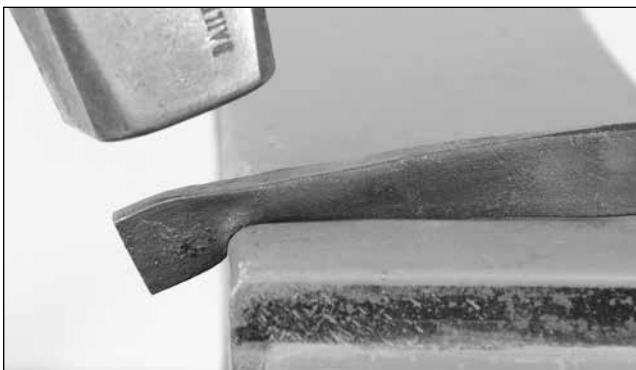

*Shoulder in half the width of the bar. That should leave you with a  $\frac{3}{8}$ " square neck*



*Finally take the neck to a round cross section without destroying the look of the taper to the parent bar*



# HA'PENNY SCROLLS

Take another heat and twist the flag through 90° while working at the vise or use two pairs of tongs at the anvil.

Staying at the soft offside edge, forge the neck down to ¼-inch thick while dressing sides of the taper as you work. This is going to extend your 3-inch-long taper to something more suitable.

The degree of taper that you create now will also run through the ha'penny finial when the scroll is finished.

Take the time to chamfer the corners now, although you get to do this again a little later.

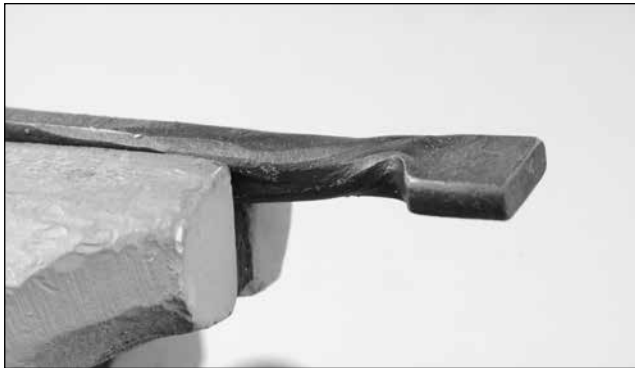

*Twist at the vise using a pair of scrolling tongs*

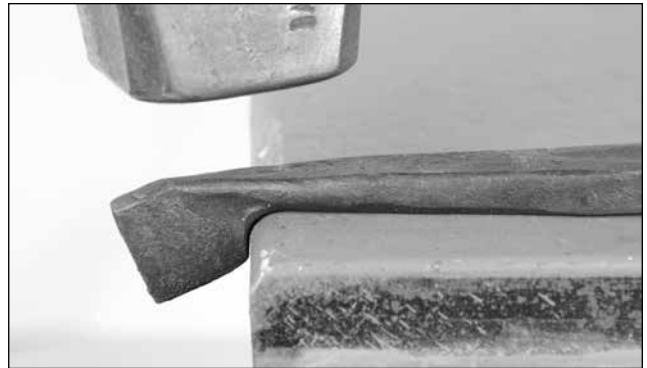

*I like to bring the tip of the taper down to just under parent bar thickness, but this is not required*

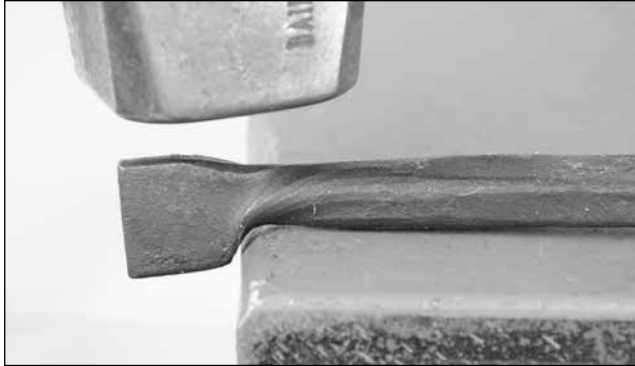

*Return to the soft, offside edge and re-establish your taper to the parent bar*



*Chamfer at least the edges of the taper. I like to chamfer the whole bar as it aids in fitting the collars*

The best round comes from the best square, and as you look at the flag, I'm betting that it is not square. The job now is to make the flag square.

Typically, the side attached to the parent bar is longest, decreasing as you work your way around the flag.

Staying at the soft edge, and keeping the bar flat on the anvil with the flag hard against the offside edge, use a glancing blow and knock the long side corner down towards the end of the bar.

The move generally doesn't require a power blow, thus the glancing blow.

# MARK ASPERY

Turn the bar over 180° and place the back of the flag on the face of the anvil.

Hold your hammer at a steep angle and pull in the second corner - again, somewhat of a glancing blow.

Dress the top of the flag so that it is parallel to the bottom.

Drop the flag over the edge of the anvil and dress the end of the flag by knocking it against the side of the anvil. Both these last moves require a bit more force as you are upsetting the material slightly.

Having the stored material (the dry clump of dirt) in front of the flag will prevent cracks from forming as you dress the flag.



*Using a glancing blow, knock in the top corner of the flag*



*Flatten the top surface until it is parallel with the surface of the anvil*



*The last move will have made the lower corner of the flag stand out*

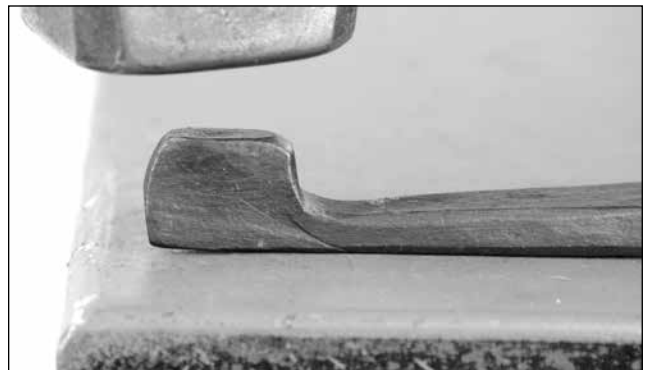

*Make sure that you take a good heat for this and the next move*

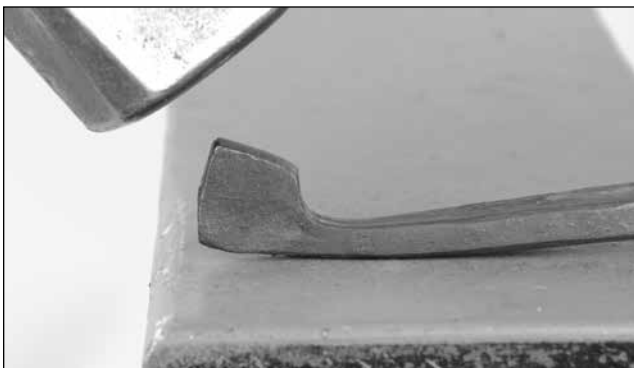

*Angle your hammer as you pull in what was the lower corner. Drop the hammer angle as you work*

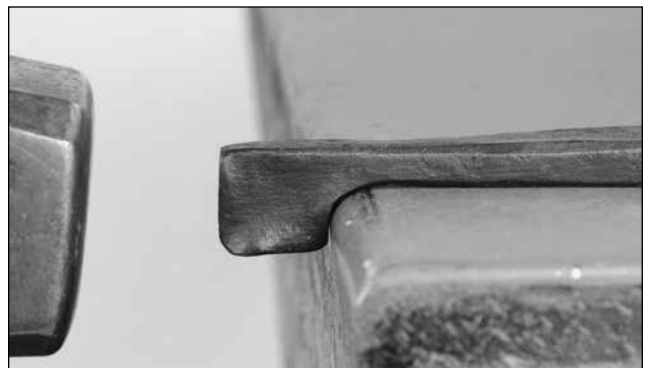

*Upset the flag to form a square of material, holding your hammer vertically as you work*

# HA'PENNY SCROLLS

Finally, dress the thickness of the flag on the anvil to achieve parallel sides. You'll create the tapered end of the scroll later.

Repeat these moves until the flag is square and has a uniform thickness.



*Hold the bar at a 45° angle to the anvil and drive in the outside corner.*



*Work near the offside edge to prevent damage to the taper as you dress the now-square flag*



*Leave room under the taper as the bar will move closer to the anvil*

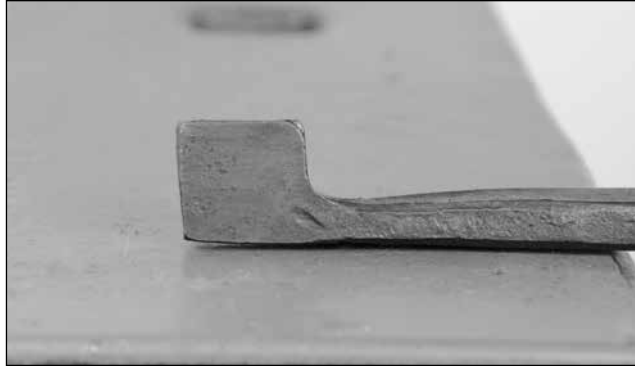

*You may have to repeat the last few steps before you have finished forging the square flag*

In theory the corner resting on the offside of your anvil will be driven in equally - alas, not in my world (see above photo).

Put the corner that you just worked, on the face of the anvil. That leaves the corner that was resting on the offside edge uppermost.

Dress the upper side to match the lower.

To create the square (flag) to round (Ha'penny) transition, you are going to use the normal square, octagon, round regime - only you must complete these moves two corners at a time.

As this is going to upset the flag material, make sure that the bar is smoking hot.

Hold the flag at 45-degrees to the offside of your anvil and drive in the outside corner.

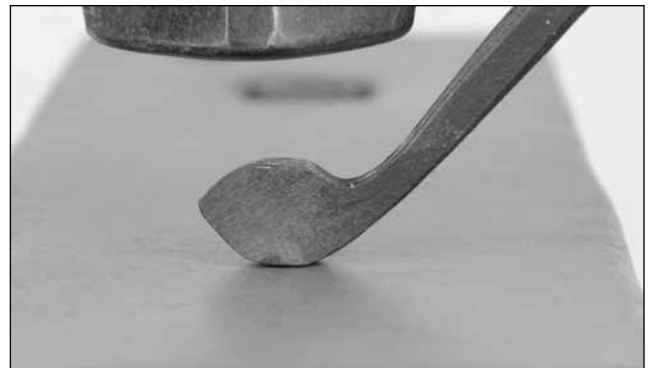

*Make sure that both flats are equal in size and shape*

# MARK ASPERY

At this stage, you have started your octagon process on two corners. You are now going to finish those corners to round - or a ¼-round, anyway.

Return to your original position with the flag at 45° over the offside edge.

Rock the bar up a little and drive in the exposed minor corner - drop the bar and repeat for the other minor corner.



*After creating the flats, knock off first one pair of corners by raising the barstock...*



*And then lower the barstock to remove the other corner. You should be left with a lemon shape*

Come back to the face and do the same to the inside corner. This shouldn't take much work - rock the flag as you forge, to avoid flat spots.

I do not dress or correct the growth in thickness on the ha'penny, preferring to do this later when I have a bigger picture available to me as to what is required to make the finial round.

Your call!

Now is when we get rid of the dirt in front of the wheel as described earlier.

Over a sharp edge (sharp being something akin to bailing or tie-wire), hang the flag over the edge and pull back until the soft shoulder of the scroll rises over the edge, and the flag is hard against the offside edge.

Deliver a half-faced blow onto the neck of the scroll, and dress the sides of the taper only and chamfer the corners, do no work to the flag.

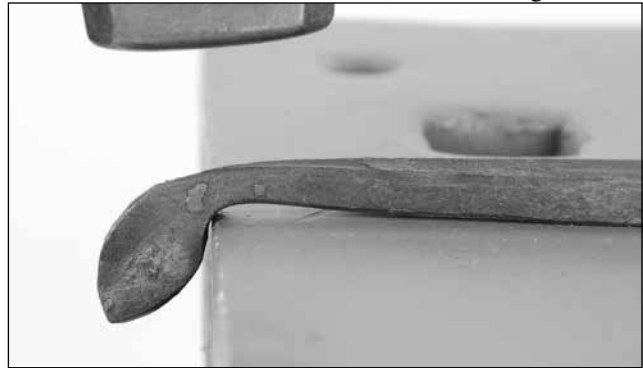

*Remove the dirt in front of the finial by driving the neck over a sharp edge of the anvil*

At this stage, you should have a teardrop shaped flag with a sharp transition to the start of the taper leading to the parent bar.

Now you need to roll the wheel slightly.

Take a heat, and resting the scroll on the flat of the taper, flag up, pull the flag towards you with your hammer, stopping before getting to 90°, or, as I like to say, leaving the flag open of 90°, just like an upset square corner.

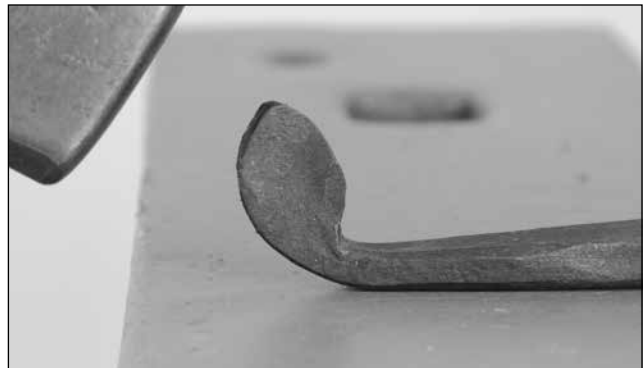

*Stand the finial up to not-quite 90°*

# HA'PENNY SCROLLS

Your next moves are to set down the remaining corner and then take the area through octagon to round.

It must be noted that during this process you also treat the area opposite equally, which means not holding it in one spot on the anvil as you perform the moves on the remaining corner.

Lift up on the bar as you flatten the remaining corner. Lift or drop down on the bar as appropriate as you blend in the minor corners of the octagon.



*Drive in the remaining corner rocking the bar back and forth as you do so, preventing a flat spot on the back*

Once that looks good to you, turn the bar on its side, and using the ball face of the farrier's rounding hammer, spread the finial in much the same way as you did with the material for the flux spoon in book one, the black book.



*Note how the taper from the parent bar extends through the scroll finial*

If you're having difficulties getting the shape that you want, there is a bottom tool that can be made to assist you.

We know that the finial should be close to 1-inch in diameter. We also know that you are going to need some room to get your hammer into the area of the bottom tool - so the tool will need to be fairly tall.

Lastly, the 1-inch half-round depression into tool needs to be against the top of the tool to allow the taper to the parent bar somewhere to go.

A curve to the top of the tool can also act as a scroll starter.

Important to note is that the transition from the finial to the taper is good as it is, and does not need to be altered. The bending for the scroll starts behind this transition, just into the taper to the parent bar.



*A tool that can be used to dress the finial. This tool is optional and not required for a great ha'penny scroll*

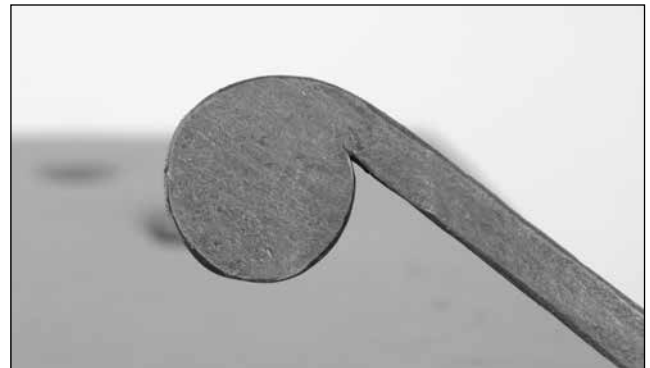

*Here is my result, ready to be turned into a scroll*

WE HOPE THAT YOU HAVE ENJOYED THIS  
COMPLIMENTARY MAGAZINE FROM THE CBA.

CONSIDER JOINING US BY BECOMING A  
MEMBER OF THE ASSOCIATION.

PLEASE VISIT [CALSMITH.ORG](http://CALSMITH.ORG) TO JOIN.

THANKS, AND WE'LL SEE YOU AT CONFERENCE.

