

**CBA/ABANA National Curriculum Master Document – All levels and resources:**

**February 2021**

The CBA curriculum is limited in its scope, and deals only with developing a blacksmith's skills in the forge environment. The lessons are exercises and usually criterion based rather than project based unless required for the Grille Projects.

The curriculum has been divided into 3 levels, with some levels have multiple subjects, each requiring considerable time requirements by the student/instructor.

Individual items have been grouped, where possible, with similar subject materials. Levels and projects can be taught out-of-sequence, and noted as complete in the student log book.

It is anticipated that the student will have some access to equipment such as:

Drill press

Machinist vice

Welder

Oxy/Fuel system

## **CBA/National Curriculum Level I – Basic Blacksmithing**

This certificate will be awarded to those who have completed the Level I, basic training or the equivalent. They will have presented to their instructor the Farm Gate Latch (see drawing) and have passed a safety test. By doing so they have demonstrated an understanding of the basic skills of a blacksmith, including:

### 1.0.1 - SAFETY

- 1.0.1.1. - Review PPEs, Eye protection, Hearing protection, Natural fiber clothing, Footwear. Everything is hot unless proven otherwise. How to check for heat in a bar.
- 1.0.1.2. - Glove related injuries (GRIs). No gloves when working on drill press, grinder/belt sander or other machinery with moving parts.
- 1.0.1.3. - No loose hammer heads or mushroomed struck ends of hand tools.
- 1.0.1.4. - Student should be able to start, tend and close-down a forge safely (regardless of fuel used).
- 1.0.1.5. - Understand local safety protocols according to the host organization or venue setting such as the CBA safety guidelines.

### 1.0.2 - NOMENCLATURE OF THE ANVIL, FOGE AND VISE

- 1.0.2.1    Develop a common vocabulary within the forge and anvil environment

### 1.0.3 - HAMMERS AND TYPES OF HAMMER BLOWS

Develop a basic understanding of the typical hammers used in a forge, their uses, and the type of blows used (full faced, half faced, fulling and shearing)

### 1.0.4 - TAPERS (square, octagon, round, chisel tip and diamond)

- 1.0.4.1 Student should understand how and where to hold material on the anvil to draw down tapers. The use of tongs should be introduced. Use of the slack tub should be introduced.
- 1.0.4.2 The square, octagon, round rule (SOR) should be understood
- 1.0.4.3 Tapers are to be a fixed length, straight sided with the ends centered along the center-line of the parent bar.
- 1.0.4.4 Student to demonstrate the knowledge of SOR and how progressing through the stages effects the length of the taper

### 1.0.5 - FORGE A STAPLE [Gate latch]

- 1.0.5.1    From a 7-inch length of  $\frac{5}{16}$ -inch round bar.  $1\frac{1}{8}$ -inch ID.
- 1.0.5.2    Two versions: chisel tip tapers and square tapers.

1.0.6 – FORGE A 'S' HOOK (fig 8).

- 1.0.6.1 from 8-inch length of  $\frac{5}{16}$ -inch round bar –
- 1.0.6.2 1-inch ID eyes.
- 1.0.6.3 Dress ends of the bar to suit

1.0.7 – FORGE LEAVES – necking-in and spreading

- 1.0.7.1 Student should understand how to 'neck-in' away from the end of a bar and spread material using a hand hammer.
- 1.0.7.2 The effects of using the cross peen, ball peen and the flat face of the hammer for spreading should be understood by the student

1.0.8 – HAND-HELD ROUND PUNCH

- 1.0.8.1  $\frac{1}{4}$ -inch diameter working end.
- 1.0.8.2 Student to understand the parameters associated with forging a hardenable steel. Forging too hot and Blue Brittle

1.0.9 – HOT-CUT CHISEL.

- 1.0.9.1 At least 1-inch wide at the working end (chisel or top tool)
- 1.0.9.2 Optional: Butcher (chisel or top tool)

1.0.10 – HAMMER-EYE DRIFT [Leafing hammer level II]

- 1.0.10.1 Student to understand the properties of a parallel sided drift – taper to both working & struck end, with no corners of the taper proud of the main body of the drift.
- 1.0.10.2 From  $\frac{3}{4}$ -inch diameter bar
- 1.0.10.3 Finish at  $\frac{1}{2}$ -inch by  $\frac{7}{8}$ -inch oval.
- 1.0.10.4 Hammer eye drift will dictate the size of the slot punch/slitting chisel. Main body, and taper to the working end should be free of hammer marks.
- 1.0.10.5 Edges of the main body to be half-round.
- 1.0.10.6 Taper to the struck end to be sufficiently long as to pass through 1-inch square bar (Monkey tool).

## California Blacksmith Association Curriculum

### 1.0.11 - SLOT PUNCH [Leafing hammer level II]

- 1.0.11.1 7/8 x 1/8 (or equivalent).
- 1.0.11.2 Student to forge a slot punch or slitting chisel (instructor's discretion) for use with the oval sectioned drift.
- 1.0.11.3 Student should understand how slot punches/slitting chisels are related in size to the intended drifted outcome.
- 1.0.11.4 Student will understand the relationship between the size of the initial slot/slit chisel, the intended drift and outcome (forged, such as drawn cheeks on a hammer head, or otherwise).
- 1.0.11.5 Working end to be perpendicular to any indexing placed in the struck end of the tool (if applicable).

### 1.0.12 - HEAT TREATMENT OF CARBON STEEL & ALLOYS.

- 1.0.12.1 At the end of this section a student should possess a rudimentary knowledge of: Annealing, Normalizing Hardening (Austenite to Martensite) Tempering.
- 1.0.12.2 Using a basic carbon steel phase diagram.
- 1.0.12.3 Student to heat treat and test hand tools

### 1.0.13 - MONKEY TOOL [Gate latch, level II and Level III]

- 1.0.13.1 From 1-inch square stock (precursor to making a hammer - level 2).
- 1.0.13.2 For 5/16-inch tenon.
- 1.0.13.3 Tool to have vent/visual hole punched and drifted using tools from 1.0.10 & 1.0.11
- 1.0.13.4 Punching and drifting the eye is a pre-cursor to making a leafing hammer.
- 1.0.13.5 The hole shall be centered in the bar and perpendicular to the center-line of the parent bar

### 1.0.14 - HAND-HELD FULLER AND SIMPLE BOTTOM FULLER. [Tenons]

- 1.0.14.1 Forge a hand-held fuller (3/8-inch) and a 'Z' shaped bottom fuller from 3/8-inch round bar (to rest on the anvil).
- 1.0.14.2 Tools are needed to isolate the material to create tenons

### 1.0.15 - ROUND TENON.

- 1.0.15.1 5/16-inch diameter, on sq, rnd and flat stock.
- 1.0.15.2 Student to be able to cut/fuller, forge and monkey a tenon without forming cracks or cold shuts on the tenon or shoulder.
- 1.0.15.3 A fillet at the tenon root is expected on the finished tenon.

## California Blacksmith Association Curriculum

### 1.0.16 – ROUND DRIFT

- 1.0.16.1 From ½-inch round bar Main body to be upset
- 1.0.16.2 Taper to struck end
- 1.0.16.3 Taper to working end
- 1.0.16.4 Working end should reflect the size and shape of the hole to be re-sized.
- 1.0.16.5 Student to understand the size and shape of the working end of the drift as relates to the size and shape of the hole that is to be re-sized/shaped.

### 1.0.17 – FORGE WELDING

- 1.0.17.1 Flux spoon with a turned eye termination.
- 1.0.17.2 Students should practice and demonstrate some competency of the basic 'faggot' weld in preparation for the latch project hook.
- 1.0.17.3 Turned eye to be centered on the handle. Student to understand the neutral axis of a bend and basic stock determination required for a bend.

### 1.0.18 – Forge welding #2 Chain [3-links]

- 1.0.18.1 3-links of chain. Each link to be made from a 6-inch length of 3/8-inch diameter rod.
- 1.0.18.2 Student will practice and demonstrate competency of the chain weld, including the chain-step-scarf.
- 1.0.18.3 Weld to be as thick or thicker than the parent stock.
- 1.0.18.4 Students can choose to leave an apex at the weld or blend the apex into the weld area

### 1.0.19 – GATE LATCH PROJECT

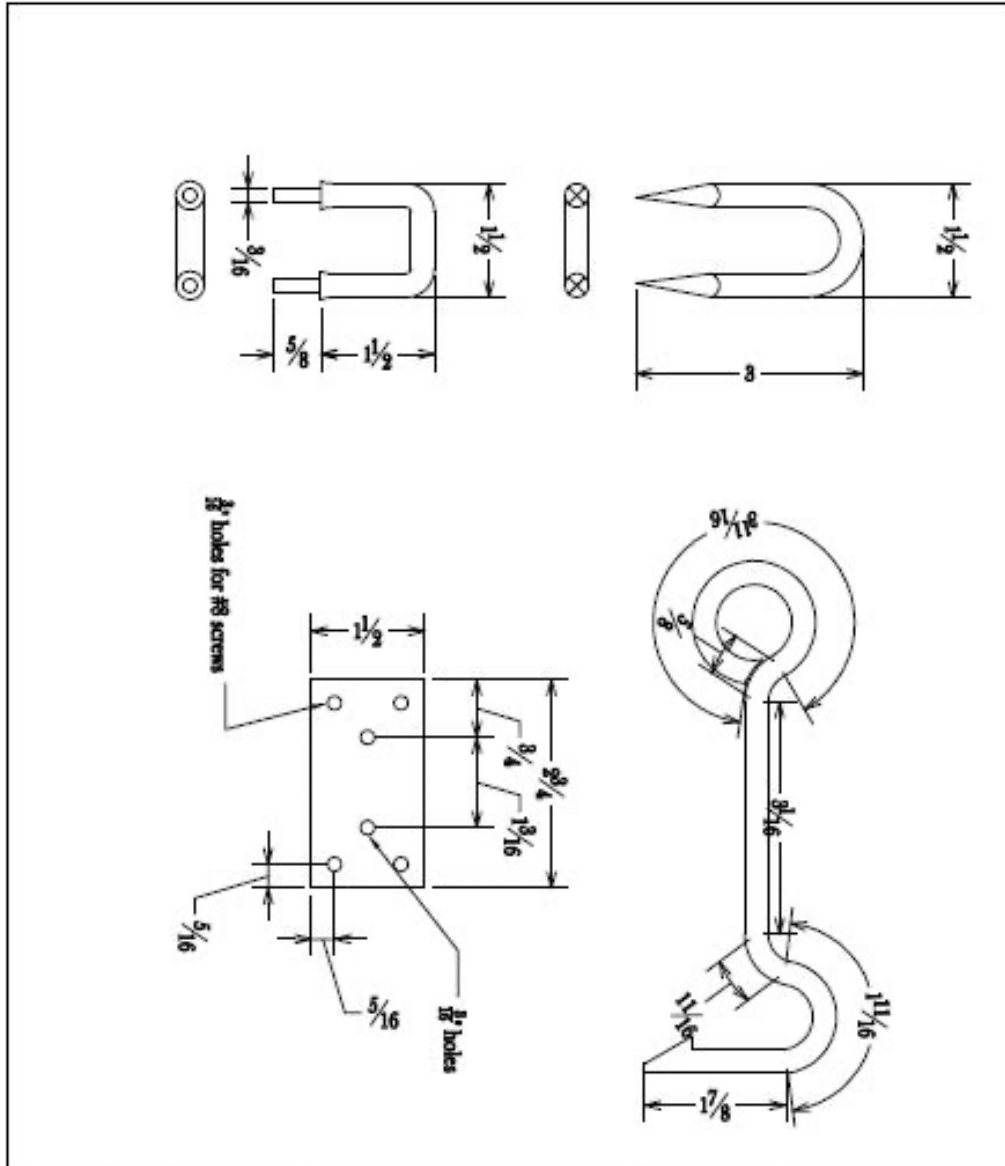

<b>McLellan Blacksmithing</b> 6961 Horseshoe Bar Road Loomis, CA 95650 (916) 652-5790 Fax (916) 652-5784 www.McLellanBlacksmithing.com	<b>Apprentice Level Project</b>			
	address			
	Gate Latch $\frac{5}{16}$ " round		Sheet Number	000
	Date	1-01-15	Revised	0-0-15
Scale	None	Drawn by	John McLellan	

## **CBA/National Curriculum Level-IIB – Tool-making**

### Level IIB

This certificate will be awarded to those who have completed the Level IIB, intermediate training. They will have presented to their instructor the various exercise pieces together with the tools listed or their equivalent, and have passed a verbal or written safety test.

#### Level IIB - Tool-Making

- Tapered Hammer-eye Drift
- Leafing hammer (Using tools from level I)
- Leafing stake
- Crimping Stake
- Chisels for cold work – Cape, Gauge and Diamond (needed for heading plate)
- Making a heading plate for bottom tools (Benchwork)
- Top and Bottom tools (case hardening)
- Welded Collar – as used in level-III Grille
- Bolster for angled pass-throughs
- Angled Pass-throughs
- 'V' Swage for punching and drifting across corners
- Student will make a pair of box jaw tongs, to fit  $\frac{3}{4}$ -inch by  $\frac{1}{4}$ -inch flat stock, with forge welded reins

*Tools made for within this level should be geared towards completing the Level-III grille project.*

### 2.1.1 - SAFETY

- 2.1.1.1. - Review PPEs, Eye protection, Hearing protection, Natural fiber clothing, Footwear. Everything is hot unless proven otherwise. How to check for heat in a bar.
- 2.1.1.2. - Glove related injuries (GRIs). No gloves when working on drill press, grinder/belt sander or other machinery with moving parts.
- 2.1.1.3. - No loose hammer heads or mushroomed struck ends of hand tools.
- 2.1.1.4. - Student should be able to start, tend and close-down a forge safely (regardless of fuel used).
- 2.1.1.5. - Understand local safety protocols according to the host organization or venue setting such as the CBA safety guidelines.

### 2.1.2. - HAMMER EYE DRIFT – TAPERED (complement to the hammer-eye drift in Level-I)

- 2.1.2.1. - The drift should reflect the same width to thickness ratio as the intended hammer handle to be fitted.
- 2.1.2.2. - The drift will carry a degree of taper that will aid in making the hourglass shape of the eye needed to secure the handle to the hammer-head.
- 2.1.2.3. - Students can start with a pre-manufactured taper, such as a 'Standard Bull-Pin" (Klein Tools Ref.# 3251), or create their own from an appropriately sized round bar.
- 2.1.2.4. - Drift does not need to be heat treated.

### 2.1.3. - GENERAL PURPOSE LEAFING HAMMER

- 2.1.3.1. - The student should forge a general-purpose leafing hammer that is to be used either at the anvil or at the vice (straight or curved body)
- 2.1.3.2. - The cross peen shall match the fullered groove of the crimping stake with an allowance for the leaf material on both sides (approx  $\frac{1}{16}$ -inch).
- 2.1.3.3. - Hammer can be made from mild steel and case hardened or from a higher-grade steel alloy and heat treated.
- 2.1.3.4. - Typical starting stock is 1-inch square bar or  $1\frac{1}{8}$ -inch (1.125-inch) round bar.

### 2.1.4 - CRIMPING STAKE

- 2.1.4.1. - Crimping stake is to be used to crimp the edges of Water Leaves forged in Level-III
- 2.1.4.1. - Student will forge a crimping stake to fit their anvil hardy hole or for use at the vise (where practical).
- 2.1.4.1. - Stake should offer enough clearance for crimping water leaves when working the outside of the leaf.
- 2.1.4.1. - The hardy stops can be made as a fold or welded collar.
- 2.1.4.1. - Scroll starter (Optional) – Where the Crimping stake is made from folded flat bar, consideration should be given to creating a scroll starter with spare bar.



2.1.5. - LEAFING STAKES

- 2.1.5.1. - The leafing stake is to be used to shape water leaves (anti-clastic raising) as in the Level-III Grille.
- 2.1.5.2. - Student will understand the use and design of a leafing stake. The student will understand that the stake can be too narrow in angle causing the leaf edges to curl over and form a pipe like form, and too wide allowing for the leaf to bend across its width during shaping, rather than the edges stretched.
- 2.1.5.3. - Stake can be forged/fabricated as needed.

2.1.6. - THREE COLD CHISELS

- 2.1.6.1. - Student will be made aware of some types of cold chisels and their usage.
  - Gouge
  - Cape
  - Diamond
- 2.1.6.1. - All cutting edges aligned for surface work. An explanation of the orientation of the cutting edge of the chisel when compared to the centerline of the tool will be given.
- 2.1.6.1. - The student will understand the difference between surface and deep work chisels e.g., the gouge being used to cut oil channels in concave bearing shells.
- 2.1.6.1. - Student will be exposed to cutting metal (stock removal) using cold chisels and files.
- 2.1.6.1. - Chisels will be heat-treated.

2.1.7. - BENCHWORK – COLD CHISELING - cut a square hole in steel plate.

- 2.1.7.1. - Drill a large hole in a thick (e.g. 1/2-inch to 3/4-inch) section of plate steel to match the student's anvil hardy hole size.
- 2.1.7.2. - Use the three cold chisels to 'cut' in the corners, converting the drilled round hole into a square hole.
- 2.1.7.3. - Square hole to be slightly larger in size than the student's anvil hardy hole.
- 2.1.7.4. - The student has the option of fabricating a heading block for use in making bottom tools, tops tools or a combination of both.
- 2.1.7.5. - If making a heading block suitable for both top and bottom tools, then drill and cut a second plate to 1 1/4-inch square hole for use in making top tools.
- 2.1.7.6. - The plate may be welded to heavy wall tubing to form a heading block.
- 2.1.7.7. - The block will have a re-enforced center that does not interfere with the use of the tool.
- 2.1.7.8. - Block must be able to be securely fastened to the face of the anvil during use.
- 2.1.7.9. - The heading block should be constructed to allow it to be used on the face of the anvil, over the main body, without danger of it falling off and causing injury.

2.1.8. - BENCH WORK – FILING.

- 2.1.8.1. - The student will be encouraged to use a file(s) such as a three-square file to clean up the square hole giving the instructor an opportunity to talk about types of file and filing techniques.

2.1.9. - CREATE ONE BOTTOM & ONE TOP TOOL.

- 2.1.9.1. - Both tools will become the swages necessary for the welded collar in the Level-III grille.
- 2.1.9.2. - A hand held fuller will be used on the top and bottom swage blanks to 'let-in' the details needed to create a matched pair of tools for use in creating a welded collar.
- 2.1.9.3. - Forge the tooling required to let in the shapes needed to create the welded collars needed in the center bar/style of the final grille project as needed.
- 2.1.9.4. - Both tools should be finished with enough height left on the working end to enable the welds to be created with ease.
- 2.1.9.5. - The top tool can be punched to accommodate a handle or rod.
- 2.1.9.6. - Both swages will be case-hardened if made from mild steel or heat-treated if made from a hardenable steel.

2.1.10.- CREATE WELDED COLLAR ON RECTANGULAR STOCK

- 2.1.10.1.- Create welded collar on rectangular stock
- 2.1.10.2.- This is a practice session for welding collars onto flat bar such as those used in the final grille project.
- 2.1.10.3.- The welded collar is round but oval in cross section and should be in the region of ½ inch wide with an OD of about 1 inch+.
- 2.1.10.4.- A section of ½ inch wide and ¼ inch thick half-round bar will be welded to a section of ¾ by 1-inch flat bar.
- 2.1.10.5.- Flat bar to be necked in prior to welding the collar' to create a round section of bar around which the collar will be welded.
- 2.1.10.6.- The student should be able to identify problems associated with trying to weld with both too much and too little collaring stock. The collars should be firmly welded without gaps at the edges or where the ends of the collar material join.

2.1.11. - ANGLED BOLSTER PLATE

- 2.1.11.1. - Fabricate or forge a bolster plate to support material for an angled pass through of square, flat or round stock
- 2.1.11.2. - The bolster should be for use at the vise, and allow clearance for the drift
- 2.1.11.3. - Student will understand the manufacture and use of a drift in making holes of a given size and shape
- 2.1.11.4. - Drift will be oversize to allow for contraction during cooling.
- 2.1.11.5. - The student will create bolster plates or swages to support the stock during drifting over the hardy hole, pritchel hole or the vise when drifting angled holes.

The bolsters will be punched and drifted to allow a clearance fit of the primary drift.

2.1.12. - ANGLED PASS THROUGHGS

- 2.1.12.1. - Student will understand the relationship between the tool used to create the initial hole, the angle required and the working end of the primary drift.
- 2.1.12.2. - Student should understand the different approaches to punching and drifting a hole in a bar, depending on the desired outcome.
  - Punch and drift
  - Punch, upset and drift
  - Upset, punch and drift
- 2.1.12.3. - Round or square bar (typically ½-inch in thickness or diameter).
- 2.1.12.4. - Student should understand how to determine bar stretch or shrinkage and how to allow for such factors during layout.
- 2.1.12.5. - Student will understand the maximum angle that can be attained using a given procedure.
- 2.1.12.6. - Student to become practiced in angled pass throughs of both round and square stock.
- 2.1.12.7. - The student should understand the limits of any techniques used
- 2.1.12.8. - The student should be encouraged to produce pass throughs that show drifting from punching and drifting an upset bar to show an increase in the sides of the eye material

2.1.13. - 'V' SHAPED BOLSTER SWAGE

- 2.1.13.1. - for use in both perpendicular & angled pass-thoughts of square bar across the corners.
- 2.1.13.2. - Perpendicular through of square bar across the corners - test pieces

2.1.14 - BOX JAW TONGS

- 2.1.14.1. - Student will make a pair of box jaw tongs to hold ¾-inch by ¼-inch flat bar
- 2.1.14.2. - Tongs will have forge welded reins
- 2.1.14.3. - Reins will taper from the boss or hinge plate
- 2.1.14.4. - Rivet to be made from round bar (3/8-inch diameter)

**CBA/National Curriculum Level-IIa - Scrolls, scroll tooling, small-scale joinery and Grille (forging to dimension).**

The CBA National Curriculum is limited in its scope, and deals only with developing a blacksmith's skills in the forge environment. The lessons are exercises and are both criterion and project based unless required for the Grille Project.

The curriculum has been divided into 3 levels, with some levels have multiple subjects, each requiring considerable time requirements by the student/instructor.

Individual items have been grouped, where possible, with similar subject materials. Levels can be taught out-of-sequence.

It is anticipated that the student will have some access to equipment such as:

Drill press

Machinist vice

Welder

Oxy/Fuel system

**Level IIa**

This certificate will be awarded to those who have completed the Level IIa, intermediate training. They will have presented to their instructor the various exercise pieces together with the grille or equivalent (see drawing), and have passed a verbal or written safety test.

Passing this level demonstrates competence in some of the Intermediate skills of a blacksmith including:

- Safety Review
- Basket Handled Poker (forge welding)
- Scrollwork and the scroll form:
  - Ribbon scroll
  - Knib end - Fish tail, bolt end
  - Snubbed end - Half Penny & solid Snub End
  - Beveled Scrolls – Beveled & Beveled Leaf scroll
- Scrolling fork (case hardening, forging to dimension)
- Scrolling Tongs (introduction to tong making, forging to dimension)
- Collars and collar mandrel/tongs (forged and wrapped collars)
- Upset square corners (upset pre and post bend, forging to dimension)
- Welded Ring (forces of tension and compression, forging to dimension)
- Punched and drifted holes (round, square & diamond holes) in square, round and flat stock.
- Complete the Level-II Grille (forging to dimension)

2.0.1. – SAFETY.

- 2.0.1.1. - Review PPEs, Eye protection, Hearing protection, Natural fiber clothing, Footwear. Everything is hot unless proven otherwise. How to check for heat in a bar.
- 2.0.1.2. - Glove related injuries (GRIs). No gloves when working on drill press, grinder/belt sander or other machinery with moving parts.
- 2.0.1.3. - No loose hammer heads or mushroomed struck ends of hand tools.
- 2.0.1.4. - Student should be able to start, tend and close-down a forge safely (regardless of fuel used).
- 2.0.1.5. - Understand local safety protocols according to the host organization or venue setting such as the CBA safety guidelines.

2.0.2. – RING PROJECT.

- 2.0.2.1 - Student will forge a welded ring out of flat bar-stock, bending the material on edge.
- 2.0.2.1 - The ring will be forge-welded shut and of a pre-specified size.
- 2.0.3.1 - Student will understand the behavior of steel when it is bent such as:  
**Compression** (and subsequent thickening of the material) on the inside of the bend and,  
**Tension** (and subsequent thinning of the material) on the outside of the bend.
- 2.0.2.1 - Student s should learn to compensate for the 'movement' of the corners, at the end of the bar that accompanies forming a ring.
- 2.0.3.1 - Student will learn to upset at the end of the bar in preparation for welding.
- 2.0.2.1 - Student will understand the need for shaping a scarf at the end of the bar and forge a welding scarf.
- 2.0.3.1 - Student will learn to use the horn for bending and truing a ring without changing the cross section of the material other than compression and tension
- 2.0.3.1 - The ring should be forged to a pre-determined size.

2.0.3. – BASKET HANDLED POKER.

- 2.0.3.1. - Students will form a basket handle from at least 4-pitches of ¼-inch diameter rod, 6-inches long.
- 2.0.3.2a. - Working in a solid fuel forge, the student will weld a collar to one end of the handle.
- 2.0.3.2b. - Working in a gas forge, the student has the option of drawing one end of the handle out into a round taper and turning an eye.
- 2.0.3.4. - The other end of the handle should be welded onto 3/8-inch square stock or 7/16-inch round stock.
- 2.0.3.5. - Student to be exposed to volume calculations for choices of shaft material to be welded to the handle.
- 2.0.3.6. - A poker end, complete with spur, must be welded to the lower portion of the shaft.
- 2.0.3.7. - Spur can be forge welded on or drawn out (as per scrolling fork).

2.0.4. – SCROLLING FORK.

- 2.0.4.1. - Forged from one piece.
- 2.0.4.2. - Mild steel case hardened or tool steel heat treated.
- 2.0.4.3. - Student must demonstrate that ability to properly allot stock for a given procedure – in this case, two tines of a scrolling fork together with a fixed gap, and a turned eye of a fixed diameter on the end of the handle
- 2.0.4.4. - Volume, area or weight calculations should be shown to assist in allotting the material to form the fork tines and gap.

2.0.5. – SCROLLING JIG.

- 2.0.5.1. - Jig will be made by free-hand.
- 2.0.5.2. - Student will forge a scrolling jig from flat bar-stock.
- 2.0.5.3. - The jig will have a flared end for the start of the scroll
- 2.0.5.4. - The jig can be flat or a helix.
- 2.0.5.5. - Student will scroll the jig free-hand at the anvil using a hand hammer and scrolling fork with horns as needed.
- 2.0.5.6. - Student will observe the dishing associated with bending flat stock the 'easy' way and will compensate for the fact through filing or prior dishing the material.

2.0.6. – RECTANGULAR FRAME FROM TWO PIECES.

- 2.0.6.1 – Student shall forge and form a rectangular frame.
- 2.0.6.2 – The frame should be made from flat stock  $\frac{3}{4}$ -inch by  $\frac{3}{8}$ -inch and fit the supplied/available level II drawing.
- 2.0.6.3 – The frame will consist of two 'L' shaped elements.
- 2.0.6.4 – The 'L' shape will have an upset square corner, with a tenon on one end with a punched round hole on the other end.
- 2.0.6.5 – Two methods of forming the square corners must be employed. One will have the upset positioned prior to the bend, the other will be upset post bending. The differences in inside corners should be discussed.
- 2.0.6.6 – Pre-bend upset:
  - Student to control the heat and length of upset.
  - The upset should be reasonably centered in the bar prior to bending and forming the corners.
  - Care should be taken to ensure that any upset is not drawn down during the forming of the corner.
  - Gusset should be of a constant radius.
- 2.0.6.7 – Post bend upset:
  - Corner will be free from any cracks.
  - Corner will be the same dimensions as the parent stock on either side of the square corner.
- 2.0.6.8 – The tenons will fit into the punched holes on the other arm
- 2.0.6.9 – Tenons can be cut using a guillotine type of tool or the hand held fuller/chisel and simple bottom fuller made in level I

## California Blacksmith Association Curriculum

2.0.6.10 – This frame will be used for fitting and collaring forged scroll examples and must fit the drawing supplied.

### 2.0.7. – SCROLLING TONGS.

2.0.7.1. – Student will forge a pair of scrolling tongs for use when creating scrolls, and fitting the scrolls to the Level-II Grille.

2.0.7.2. – Tong reins may be drawn down or forge welded on

2.0.7.3. – Student to finish this section with a basic understanding of how to forge a pair of tongs, including matched jaws, matched bosses or hinge plates, adjusting the jaws and reins to fit.

### 2.0.8. – SCROLLS.

2.0.8.1. – Ribbon scroll

2.0.8.2. – Knib-ended scrolls - Bolt ended scroll, Fish Tail

2.0.8.3. – Snub ended scrolls - Half-Penny scroll & Snub-End scroll

2.0.8.4. – Beveled scrolls & Blown-over Beveled Leaf scrolls:

Student will learn to turn beveled scrolls at the anvil.

The student will understand how to turn left and right facing beveled scrolls.

2.0.8.5. – Student will demonstrate a basic proficiency at forging various scroll ends.

2.0.8.6. – An emphasis will be placed on the student to form (at least the start) the scroll freeform using a hand hammer adding scrolling fork and horns as necessary.

2.0.8.7. – Scrolls will be free from straight sections and kinks along the length of the formed scroll.

2.0.8.8. – A scroll form can be used if required, provided that the student made the scroll form.

2.0.8.9 – Student will note that a scrolling jig will have to be purpose built to accommodate the bolt and snubbed scroll ends

2.0.8.10. – Students will fit two 'S' shaped scrolls back to back within the already completed rectangular frame.

2.0.8.11. – An example of each type of scroll should be included within the grille: Beveled, Snubbed, Ribbon & Knib

2.0.8.12. – The scrolls will be collared where they touch each other and either riveted or collared to the frame

### 2.0.9. – COLLARS.

2.0.9.1. – Student will understand the attributes of a collar mandrel or collaring tongs. Such as tapered end to allow for easier collar removal and chamfered edges.

2.0.9.2. – Student will forge at least one collar over a mandrel or collaring tongs to achieve square corners both inside and out. The other collar can be wrapped with either blunt or tapered ends

2.0.9.3. – Student will understand the basic formula for determining the length of stock needed for a collar and be able to manipulate that information as the stock cross section changes, such as the center collar in the level III grille project.

2.0.9.4. – Test collars are to be encouraged.

2.0.10. – DRIFTS.

- 2.0.10.1. – Student will understand the manufacture and use of a drift in making holes of a given size and shape.
- 2.0.10.2. – A square and diamond drift are to be made to compliment the round drift made in Level I.
- 2.0.10.3. – Drift can be made from mild steel or a higher-grade steel alloy
- 2.0.10.4. – Drifts must be over-size to allow for 'off-the-shelf' ½-inch square bar-stock to pass through the drifted holes when cold.
- 2.0.10.5. – Square drift to exhibit a round taper to the working end
- 2.0.10.6. – Diamond drift to exhibit a slot-punch or slitting chisel taper to the working end

2.0.11. – BOLSTER PLATE

- 2.0.11.1 – The student will create bolster plates or swages to support the stock during drifting over the hardy hole, pritchel hole or the vise.
- 2.0.11.2. – The bolsters will be punched and drifted to allow a clearance fit of the primary drift.
- 2.0.11.3. – Student will understand the relationship between the tool used to create the initial hole and the working end of the primary drift.
- 2.0.11.4. – Student should understand the different approaches to punching and drifting a hole in a bar, depending on the desired outcome and stock used:
  - Punch and drift
  - Punch, upset and drift
  - Upset, punch and drift
- 2.0.11.5. – Student should understand how to determine bar stretch or shrinkage and how to allow for such factors during layout.

2.0.12. – PUNCH AND DRIFT.

- 2.0.12. – Student to punch and drift holes in bars of difference cross section
- 2.0.12. – Punched and drifted holes to be perpendicular to the bar.
- 2.0.12. – Three punched and drifted holes, one each of:
  - Round,
  - Square and
  - Diamond holes
- 2.0.12. – Each hole to be punched and drifted through:
  - Square bar
  - Round bar
  - Flat bar
- 2.0.12. – Student to be encouraged to upset one or more bars in the area of the proposed hole prior to punching.
- 2.0.12. – Use of a half-round bottom swage is encouraged when punching through round bar.



2.0.12. – When punching and drifting the square hole, the student should be encouraged to punch, upset and then drift the hole, creating a thicker side wall.

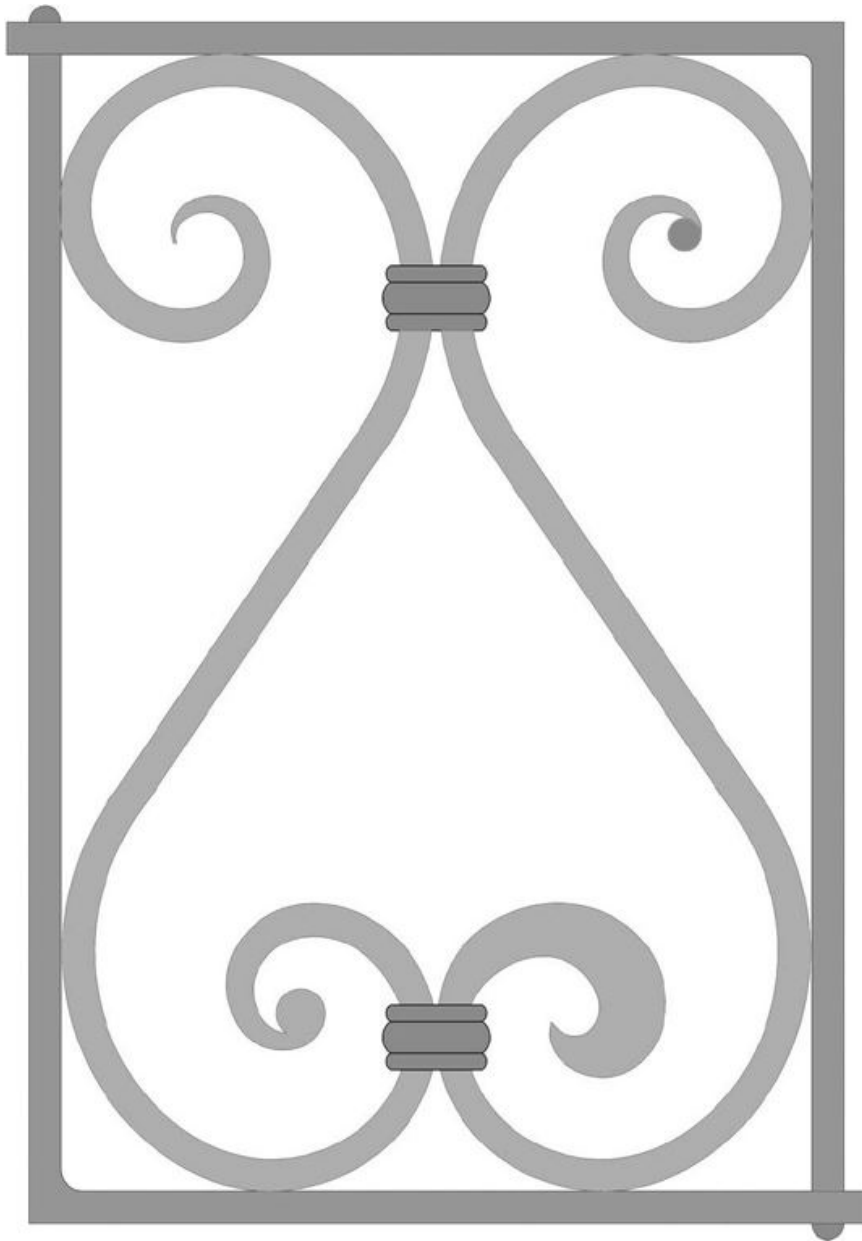

### **CBA/National Curriculum: Level IIIA Grille**

#### 3.0.1. – SAFETY

- 3.0.1.1. - Review PPEs, Eye protection, Hearing protection, Natural fiber clothing, Footwear. Everything is hot unless proven otherwise. How to check for heat in a bar.
- 3.0.1.2. - Glove related injuries (GRIs). No gloves when working on drill press, grinder/belt sander or other machinery with moving parts.
- 3.0.1.3. - No loose hammer heads or mushroomed struck ends of hand tools.
- 3.0.1.4. - Student should be able to start, tend and close-down a forge safely (regardless of fuel used).
- 3.0.1.5. - Understand local safety protocols according to the host organization or venue setting such as the CBA safety guidelines.

#### 3.0.2. - GRILLE

- 3.0.2.1. - Student will use tools and skills learned previously in the level I & Level II curricula to produce the grille project as per the supplied/available drawing.
- 3.0.2.2. - Students to be encouraged to use two methods of forging water-leaves:
  - The first method of completing a water leaf shall show an 'Appliqué' method of application, with a box weld completed over a section of bar that contains a scroll on the end.
  - The second leaf shall be made by spreading a bar on the other end from which a beveled leaf scroll has been made. The bar shall be cut and folded back on itself, and finished by welding the joint closed.
  - Both sets of water-leaf/scroll-end should be further welded on to the remainder of the scroll.
- 3.0.2.3. – Grille will match the supplied drawing
- 3.0.2.4. – Students to understand the scoring standards use to assess the grille prior to starting

#### 3.0.3 – TOOLING REQUIRED

- 3.0.3.1. – Student will make, and produce for assessment, tooling required for the completion of the grille:
  - Central collar swage – used both for making the center collar material and for fitting the collar to the grille
  - Top tool for fitting the central collar – this may be hand-held, handled or rodded.
  - All other tooling required for the completion of the grille should have been made, and graded previously, in earlier levels.

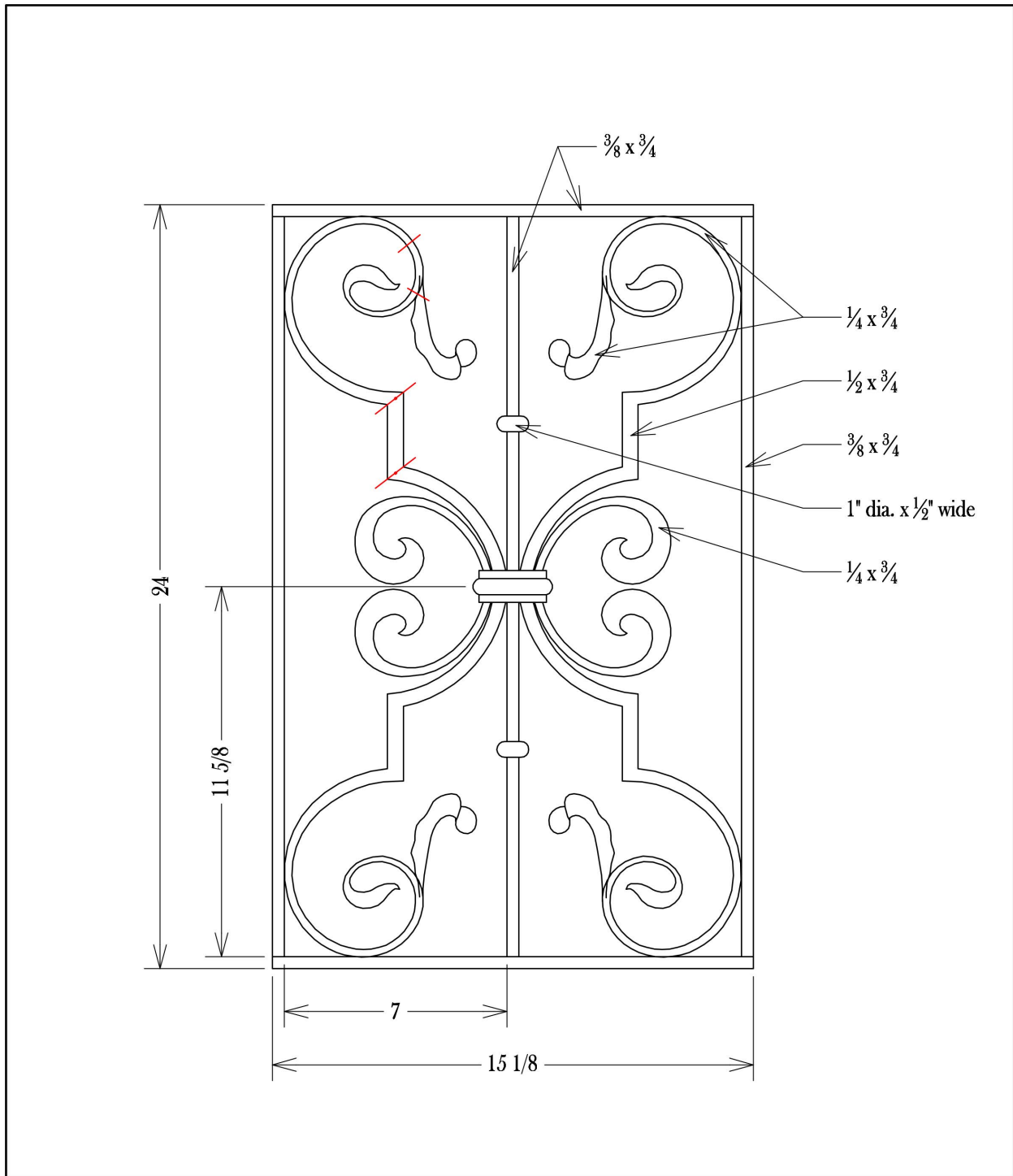

<p><b>McLellan Blacksmithing</b>                  6961 Horseshoe Bar Road                  Loomis, CA 95650                  (916) 652-5790 Fax (916) 652-5784                  www.McLellanBlacksmithing.com</p>		<b>CBA Curriculum Level III Grille project</b>			
		Grill		Sheet Number 000	
		Date 09/08/07	Revised	02/17/11	
		Scale 3" = 1'-0"	Drawn by	John McLellan	

Assessment:

Curriculum Level III Grille Assessment: 70% to pass.

Grille

1. \*Water leaves – 10 points
  - a. Overworked?
  - b. 'U' cross section – does the scroll lay within the leaf
  - c. Scroll shaped, with the tip pointing back to the main leaf
2. \*Faggot and Lap welds (taken together) – 10 points
  - a. Clean – no evidence of burning, not overworked
  - b. Complete – scarf ends are fully welded into the bar
  - c. Accuracy – scrolls are uniform in length, thickness and width
3. \*Collar welds – 10 points
  - a. Clean – no evidence of burning, not overworked
  - b. Flashing?
  - c. Complete
  - d. Parent bar overly thinned
4. \*Upset corners – 10 points
  - a. Full thickness
  - b. Sharp outside corner
  - c. Appropriate angle
5. \*Beveled leaf scrolls – 10 points
  - a. Overworked
  - b. Bevel not defined
  - c. Scroll too loose, not to drawing
6. \*Beveled 'C' Scrolls – 10 points
  - a. Bevel not defined
  - b. Overworked
  - c. Not to drawing
7. \*Center Collar – 10 points
  - a. Correct fit
  - b. Overworked
  - c. Matches tooling (below)
  - d. Elements secure
8. \*Frame details (tenons and punched/drifted mortices) – 10 points.
  - a. Square/level
  - b. Does it fit the drawing – accuracy and proficiency?
  - c. Do the scrolls touch the frame at all required points –
  - d. Do the Water leaves all look reasonably the same
  - e. Are the tips of the scrolls correct – pointing the right way, complete
  - f. Does the Grille mirror image – top to bottom, left to right

## California Blacksmith Association Curriculum

9. \*Finish – 10 points
  - a. Tool marks – free of
  - b. Scale – free of
  - c. Removal of sharp areas
  - d. wax
  
10. Bottom tooling (Collar) – 5 points
  - a. Edges relieved
  - b. Robust construction
  
11. Collar fitting top tool – 5 points
  - a. Appropriate to the intended work –
  - b. Fits the collar material

Where a judge sees an entrant close to, but not passing at 70% grade, the judge can ask the entrant to perform a task(s) incorporated within the presented grille that is/are below a passing grade – emphasizing what the judge expects to see. If the entrant makes the piece(s) to a satisfactory standard, within a reasonable timeframe – the judge can issue a pass for the Grille.

### **CBA/National Curriculum - Level IIIA grille**

#### **TOOLS AND MATERIALS:**

If you are about to embark on the CBA level III grille project, there are some supplies that you will need to gather before you start.

#### **Stock requirements:**

The grille uses three main sizes of steel, and a couple of short lengths of other sizes:

- 1/4-inch by 3/4-inch flat bar for the scrolls and water leaves
- 3/8-inch by 3/4-inch flat bar for the screen frame and center divide
- 1/2-inch by 3/4-inch flat bar for the upset corners and portions of the scroll
- 3/8-inch square stock for the welded collars
- 5/8 or 3/4-inch square stock for the central collar

We recommend tongs for each size, with preference given to box jaw tongs for flat stock and V-bit tings for square stock

It can be useful to have a pair of open jaw tongs for 1/2-inch material to aid in forging the upset square corners.

#### **The Grille Drawing:**

The drawing, downloaded from the resource's menu of the CBA website, will be transferred onto a piece of slightly rusty sheet steel.

It is useful if the sheet steel has some small holes in the corners to accept thumb tacks, enabling you to tack the drawing to the sheet steel.

Transferring the drawing gives you the ability to offer up the hot scrolls as you are working on them, and check their fit to the drawing.

A piece of blackboard chalk, some thumb tacks and a red ball-point pen will also be required for the drawing transfer. Some brown paper, such as a used paper bag from the supermarket can be useful in the drawing transfer. The brown paper is chalked on one side and placed between the drawing and the rusty sheet steel – and makes for a softer surface for the ball-point pen.

A small pair of dividers or compasses will be needed to take measurements from the drawing. A map measuring tool (Opisometer) reading in inches can be a little more accurate if you're the type of person that obsesses on the details (that's me).

A calculator for volume calculations.

#### **The Water Leaves:**

A leafing hammer with a 3/8-inch thick peen.

A crimping tool with a 1/2-inch, half round recess.

A leafing stake – which can be as simple as a 3/4-inch to 1-inch wide piece of pipe (4-inch diameter is fine) with a section of the wall cut out and replaced with a 'V'-shaped piece of steel (see photograph).

#### **Top & Bottom Tools:**

A heading block or swage block to make the bottom and top swages needed for the center collar and welded collars. You can make the block or purchase it ready made. Here is a link to a YouTube showing how to make your own

<https://youtu.be/g3ON7rRTRp4>.

Ball and Chain Forge make a commercially available heading block ([ballandchainforge.com](http://ballandchainforge.com)) or you can get something like a Centaur Forge Swage block (pattern B) and have that mounted to a stand.

The bottom swages are made from short lengths (4 ½-inches for me) of 1 ¼-inch square mild or cold rolled steel. Tongs to suit are an advantage, as are ¾-inch or 1-inch V-bit tongs for holding onto the draw down peg of the swage when working on the block.

A 3/8-inch fuller or length of 3/8-inch round bar for creating a 3/8-inch half-round groove for the welded collar, and a ½-inch fuller (or round bar) for the central collar.

A short length (10-inches) of ½-inch thick by 1-inch wide flat bar is also required when making the swages for the welded collar.

As the scrolls are of the beveled type, you will not be able to use a scroll-jig. A pair of scrolling wrenches, with one locked in the vise and the other in the hand, are required for turning the scrolls.

**Stock:**

- ¼-inch by ¾-inch flat bar – 20ft
- 3/8-inch by ¾-inch flat bar – 20ft
- ½-inch by ¾-inch flat bar – 20ft
- 1 ¼-inch square bar – 3ft
- 3/8-inch square bar (for welded collars) 3ft
- ¾-inch square stock (for central collar)

**Tools:**

- Drill for drilling rivet holes in the frame and scroll with a ¼-inch drill-bit
- ¼-inch diameter rivets ¾-inches long
- Flux and flux spoon
- Scrolling wrenches
- Top tool for collar material
- Leafing hammer
- Crimping stake
- Leafing stake
- Monkey tool (5/16-inch) for the frame
- Some form of tenon making equipment for making the tenons of the frame
- A round punch for punching the holes in the frame

### **CBA/National Curriculum: Level IIIB - Large Scale Joinery**

#### Objectives:

Students should finish this level with the necessary skills to build a pedestrian gate, a small sign holder or a screen, where the force of Tension and Compression exist.

#### Skills to include:

- Heel tenons
- Square or rectangular blockings
- Hinge journals
- Punching and drift large stock

Students will make a sample hinge style showing the above items.

#### 3.1.1. - SAFETY

- 3.1.1.1. - Review PPEs, Eye protection, Hearing protection, Natural fiber clothing, Footwear. Everything is hot unless proven otherwise. How to check for heat in a bar.
- 3.1.1.2. - Glove related injuries (GRIs). No gloves when working on drill press, grinder/belt sander or other machinery with moving parts.
- 3.1.1.3. - No loose hammer heads or mushroomed struck ends of hand tools.
- 3.1.1.4. - Student should be able to start, tend and close-down a forge safely (regardless of fuel used).
- 3.1.1.5. - Understand local safety protocols according to the host organization or venue setting such as the CBA safety guidelines.

#### 3.1.2. - HEEL-TENON MONKEY TOOL & CORRESPONDING DRIFT, OR A SIDE SET & DRIFT.

- 3.1.2.1. - Student should forge or fabricate either:
  - A Monkey-Tool for monkeying the shoulder of an oval heel tenon and the corresponding oval drift.
  - A Side-Set for use in dressing the shoulder of an oval heel tenon and a corresponding drift.

#### 3.1.3. - HEEL BAR WITH HEEL TENON

- 3.1.3.1. - Student to produce a sample heel bar with heel tenon to fit the sample hinge style
- 3.1.3.2. - Heel bar to be forged by either by an upset & cut method or a forge welded & cut method.



3.1.4. - SQUARE & RECTANGULAR BLOCKINGS ON FLAT STOCK

- 3.1.4.1. - Student to create a square and rectangular blocking on two short lengths of bar.
- 3.1.4.2. - Bars need be tenoned on the end to fit the sample hinge style with the student demonstrating the ability to cut and forge various shaped tenons on rectangular bar-stock. The tenons should be formed in such a way that the student can demonstrate that the shoulder is in a previously described position on the bar
- 3.1.4.3. - Student to make a square drift no smaller than 5/8-inch square
- 3.1.4.4. - Student to make a rectangular drift no smaller than 1-inch by 3/8-inch
- 3.1.4.5. - Student to make a slot-punch or slitting- chisel to match square and rectangular blockings

3.1.5. - PUNCHED HOLES ON A HEEL BAR OR HINGE STYLE.

- 3.1.5.1. - Student to demonstrate the ability to punch both round and square holes on either the heel-bar or hinge style of a small gate.
- 3.1.5.2. - Holes to be punched in a moderately heavy section of flat bar-stock, such as a heel bar.
- 3.1.5.3. - Holes to be sized to accommodate tenons suitable for a middle rail or style.
- 3.1.5.4. - The punched holes need to be at a prescribed distance apart to allow the student to demonstrate the ability to compensate for any change in the bar-stock length. With the student performing a test piece and recording any changes in length of the bar.
- 3.1.5.5. - The square holes can be punched with a square punch or punched round and drifted square.  
A layout of multiple holes should be performed, showing an understanding of how to accommodate for and change in bar length

3.1.6. - HINGE STYLE SAMPLE FOR A SMALL PEDESTRIAN GATE

- 3.1.6.1. - Student to produce a small sample of a hinge style that contains the items below.
- 3.1.6.2. - Punched and drifted eye to match heel tenon of 3.1.3 detailed above
- 3.1.6.3. - Punched hole to accommodate two middle rails. Middle rails to contain the square and rectangular blockings of 3.1.4. detailed above
- 3.1.6.4. - Upper hinge journal cut, chiseled and filed to round
- 3.1.6.5. - Strap and bar to finish the upper hinge
- 3.1.6.6. - Lower hinge to be either a tenon on the bottom of the hinge style or a peg (tenon) fitted to a ground plate.
- 3.1.6.7. - The hinge style can be drilled or punched to accommodate the peg

### **CBA/National Curriculum - Level IIIC Repoussé**

- This level calls for a student to make both the tools for either stake or pitch repoussé together with a small sample piece.
- For Stake repoussé, the student will make repoussé stakes sufficient in number to produce a small Acanthus leaf or similar piece of a classic design, found in either the British Catalogue of Drawing or the ABANA Anvils Ring Spring 1983 Vol 11 Number 1 The 10<sup>th</sup> Anniversary Issue.

#### 3.2.1. – SAFETY REVIEW.

- 3.2.1.1. - Review PPEs, Eye protection, Hearing protection, Natural fiber clothing, Footwear. Everything is hot unless proven otherwise. How to check for heat in a bar.
- 3.2.1.2. - Glove related injuries (GRIs). No gloves when working on drill press, grinder/belt sander or other machinery with moving parts.
- 3.2.1.3. - No loose hammer heads or mushroomed struck ends of hand tools.
- 3.2.1.4. - Student should be able to start, tend and close-down a forge safely (regardless of fuel used).
- 3.2.1.5. - Understand local safety protocols according to the host organization or venue setting such as the CBA safety guidelines.

#### 3.2.2. – REPOUSSÉ HAMMER

- 3.2.2.1. - Student will make a repoussé hammer(s) to accompany the method of repousse used.
- 3.2.2.2. - The hammer shape should reflect the intended location of use, either at the bench, anvil or at the vise.
- 3.2.2.3. - For the acanthus leaf project, one end of the hammer must be suitable for 'cleaning' up diverging/converging veins

#### 3.2.3. – REPOUSSÉ TOOLS

- 3.2.3.1. - Student will forge and finish a basic set of repoussé for use at the pitch bowl, vise or anvil.

#### 3.2.4. – ACANTHUS LEAF PROJECT

- 3.2.4.1. - Student will forge & form an Acanthus leaf of a classic design from ferrous material. The material shall be no thinner than 1/16<sup>th</sup> of an inch thick
- 3.2.4.2. - Student will understand the relationship between the width and crown of a tool end and the degree of curve that it can be made with it.
- 3.2.4.3. - Student will understand the relationship between the thickness and dressing of a tool end and the width of the vein that can be raised with it.
- 3.2.4.4. - Tooling will be made to shape the lobes of the leaf ends
- 3.2.4.5. - A veining tool or hand held fuller can be used to start the veining process.
- 3.2.4.6. - The veins, piping and eyes will be finished over the repoussé stakes

### Guidelines for Assessing Students Work

To assure a certain level of quality and consistency these guidelines should be used to evaluate a student's work before instructors sign off on any skill.

#### **Forging**

Drawing down, Upsetting or Spreading the material thereby changing the cross section of the bar

**Tapers:** Free of hammer marks, straight sided, centered on the bar and following the Square, octagon round method of forging.

**Spreading:** Free of holes and tears. Be of a uniform thickness where appropriate.

**Shoulders:** Change of stock cross-section

-Set transition (Definition; shoulder looking like it was made using a set hammer or edge of the anvil) One distinct shoulder (no chatter from miss aligned starts), free of cracks.

-Necking in (Definition; gradual transition from one cross-section to another) Smooth and free of hammer marks. Centered on the bar where appropriate

**Upsets:** Free of cracks, free of lipping and cupping, centered on the bar where appropriate

#### **Forming**

Bending or Twisting

##### **Square corners**

Upset post-bend: Free of cracks at the inside corner. Full stock width and thickness at the corner. Full stock size on both sides of the corner. The outside of the corner is to be sharp.

Pre-bend upset: Inside of corner to show a large curved fillet. The outside of the corner is to be sharp.

Square corners using a set-transition: (Definition, where the stock on one side of the corner has been reduced in cross section prior to making the corner.) The outside corner is not drawn over with the bend.

**Scrolls:** No cracks at the scroll end (such as behind snub ended scrolls). Free of kinks or straight sections. Smooth decrease in radius from the outside to the inside of the scroll.

**Scroll jig:** Should show a method of grasping the scroll end in preparation for turning the scroll. This can be in the form of a tab of material protruding from the jig or a jig of a helix construction.

## Cutting

### Splitting or Punching

**Punched hole:** Centered in the bar (where appropriate). Sides of the hole should be of a uniform thickness and shape and not thinned to a point of weakness.

**Punched and drifted hole:** Centered in bar where appropriate. Straight in its orientation to the bar. Free of cracks. Show no evidence of the initial punched or chiseled hole.

**Splitting:** Uniform sides, free from rag, protected root (half round to prevent cracking). Where a split is opened out (as in a fork) the student is encouraged to neck-in (fuller) at a distance equal to the thickness of the sides of the split, behind the split, to prevent cracking.

**Pass throughs:** Holes should be of a sufficient size and shape to allow the pass-through bar to move easily without being sloppy. Evidence of the initial slit or slot is deemed to be an incorrect match of tooling.

## Joining

**Forge weld:** The ideal forge weld is one that is completely blended in to the bar with no evidence of a joint, tolerance is given to the student if there is some evidence of the weld seam post welding.

Cracks caused by overheating or taking an excessive number of heats are not acceptable. Cracks at either toe (of the scarf) are not acceptable. A reduced cross section of the bar compared to the surrounding stock is not acceptable.

**Riveting:** Rivets should show a sufficiently large mass at the head to prevent them from being pulled from the work. The rivet head should be centered about the main body of the rivet. It is desirable that rivets be made by the student rather than store bought.

## Specific points:

**General work:** The projects and exercises set out below should be returned free of cracks, burns and gross hammer-marks in the bar. The items can be finished with a file, but not ground (except the faces of the leafing and repousse' hammers). Work ground with an abrasive will not be accepted.

**Hammer marks in the bar:** Using a hand hammer at the anvil will produce a hammer texture on the bar. Excessive texture is defined as one leaving an uneven finish or where one edge (side) of the hammer has left a visible mark in the bar (such as found when not matching the angle of a taper when drawing down a bar and the heel of the hammer is

leaving steps in the bar). A smooth hammer texture is expected in the work, but marks from erratic hammering or from the edge of the hammer are not.

**Over-forged or over-heated:** This description is given to any work that has been overly hammered or heated too many times or burned in the fire. The piece will be too thin for its intended use and may have cracks present in the bar. Students should be asked to repeat the project using fewer blows or heats.

**Finish:** Projects may be finished in a wax, oil or clear coat finish

**Water leaves:** Free of holes and cracks/tears. Crimps match (opposite each other). The end of the leaf must show a 'return' to the main leaf. Leaves should show a 'U' shaped channel to allow the placement of a scroll where needed. Edges should be thinned sufficiently to give the leaf a delicate image visually without being over-forged or containing tears.

**Acanthus leaves:** Free of holes or cracks and tears. Match curve of scroll

**Leafing Hammer:** The eye must to be drawn (checks).

**Tenons:** Free of cracks and cold shuts and has a fillet at the root of the tenon at the shoulder, to prevent the formation of stress risers

**Tongs:** Must grab the intended stock firmly. Jaws of a suitable thickness for the job/size in hand, jaws to finish in the boss and not out-in-front of the boss, reins taper (already defined above) from the boss in both directions and match in length and cross section along their length. Boss or hinge plates to be of equal size and shape.

It is not necessary that the reins/jaws open past 90 degrees so long as they open sufficiently to allow the work to be grasped easily. The jaws should be of equal length and thickness where appropriate.

Reins should be of a size and shape to allow some spring, but not bend, when holding the work during forging.

**Struck tools:** The sides of the eye should be of a sufficient thickness to resist the blows of the smith or striker.

**Resources:**

CBA/ABANA safety guidelines

Wrought Ironwork – British publication. Available as a PDF download on the web (Formerly published under: CoSIRA, Rural Development Commission, The Countryside Agency and others) Global search.

Mark Aspery - Mastering the Fundamentals books, Vols-I, II & III

Jack Andrews – The New Edge of the Anvil

Fridolin Wolf – The ABCs of Blacksmithing

ABANA – Controlled Hand Forging – available from abana.org website

Tempil - Basic Guide to Ferrous Metallurgy – Global search

Full scale Drawings of the CBA level II and level IIIA grille – available for CBA members as a PDF download from the CBA website [www.calsmith.org](http://www.calsmith.org)

**YouTube Playlist URLs:**

Level I – Basic Blacksmithing

[https://www.youtube.com/playlist?list=PL0\\_1OzAA4gHU\\_CuoGBtRm1p8JO1rUMh3E](https://www.youtube.com/playlist?list=PL0_1OzAA4gHU_CuoGBtRm1p8JO1rUMh3E)

Level IIA – The Level II Grille

[https://www.youtube.com/playlist?list=PL0\\_1OzAA4gHVA0bXd2tdK2nHEfR-BeVlf](https://www.youtube.com/playlist?list=PL0_1OzAA4gHVA0bXd2tdK2nHEfR-BeVlf)

Level IIB – Tool-making

[https://www.youtube.com/playlist?list=PL0\\_1OzAA4gHU8vzLbAwSmZoMopzJy31oW](https://www.youtube.com/playlist?list=PL0_1OzAA4gHU8vzLbAwSmZoMopzJy31oW)

Level IIIA – The Level III Grille

[https://www.youtube.com/playlist?list=PL0\\_1OzAA4gHUmn8FsAX1xpQODFy5atrTX](https://www.youtube.com/playlist?list=PL0_1OzAA4gHUmn8FsAX1xpQODFy5atrTX)

level III A – Coaching Sessions: *To accompany a course of instruction.*

Zoom Session #1:

- Drawing transfer <https://youtu.be/aHUGL2qcXbQ>
- Creating the blown-over beveled-leaf scroll <https://youtu.be/G4pCvGARdVI>
- Spreading the Waterleaf <https://youtu.be/hKZI5CEwoek>

## California Blacksmith Association Curriculum

- Raising the Waterleaf <https://youtu.be/QiDKWLk0zyk>

### Zoom Session #2

- Volume/Area calculations for starting stock length <https://youtu.be/FabyS1Gc2sU>
- Upset corner bends <https://youtu.be/DVEEJ8PpXFg>

### Zoom Session #3

- Forging a Bottom Tool Blank [https://youtu.be/aPstlbse-\\_o](https://youtu.be/aPstlbse-_o)
- The Welded Collar Tooling [https://youtu.be/9hIMzdR\\_8UU](https://youtu.be/9hIMzdR_8UU)
- The welded Collar <https://youtu.be/CSpKd1HYv34>

### Zoom Session #4

- Turning the Blown over beveled leaf scroll [https://youtu.be/\\_65xrl\\_Ahls](https://youtu.be/_65xrl_Ahls)
- The Center Collar Material Swage <https://youtu.be/YTtQk5OEFfk>
- The Beveled Scroll <https://youtu.be/iibYMrfMXs0>

### Zoom Session #5

- Tenons <https://youtu.be/hoV54-Db-NY>
- Putting the Grille together

### Level IIIB – Large Scale Joinery

[https://www.youtube.com/playlist?list=PL0\\_1OzAA4gHXI4iR3jGnPN7GPY94dl3a4](https://www.youtube.com/playlist?list=PL0_1OzAA4gHXI4iR3jGnPN7GPY94dl3a4)

### level IIIC – Repousse

[https://www.youtube.com/playlist?list=PL0\\_1OzAA4gHXWrtxKzmU4mFqr13dCsPiF](https://www.youtube.com/playlist?list=PL0_1OzAA4gHXWrtxKzmU4mFqr13dCsPiF)

## California Blacksmith Association Curriculum

### Level II: - Recordings of Zoom Tutorials

#### Basket handle YouTube links:

- Part 1 – faggot weld: [https://youtu.be/owKtfBdF8\\_A](https://youtu.be/owKtfBdF8_A)
- Part 2 – drop tong: <https://youtu.be/erU0F2UGDRQ>
- Part 3 – Collar weld: <https://youtu.be/Lr34g8XL-IA>
- Part 4 – Poker end: <https://youtu.be/w4alsbXwePY>

#### Tongs:

- Part 1 – Open Jaw tongs <https://youtu.be/O-sQP-T9iYk>
- Part 2 – What can go wrong <https://youtu.be/5RDUMBrZWM0>
- Part 3 – Forge welding reins <https://youtu.be/XpTpRf6uXi8>
- Part 4 – Rivet & adjustment, Box jaw <https://youtu.be/lsybHEEazrl>

#### Hand tools:

- Part 1 - Scrolling Wrench: <https://youtu.be/M6dDYkXKPts>
- Part 2 – Struck end and Hot-cut chisel <https://youtu.be/i1IxNNV7eZk>
- Part 3 – Hammer-eye drift and slot punch <https://youtu.be/336Pv5xzYhQ>
- Part 4 – Tenon tools and monkey tool <https://youtu.be/KX7YruJ0mWw>

#### Tenons on flat bar:

- Coaching session <https://youtu.be/hov54-Db-NY>